

WILLS WING



Falcon 140, 170, 195, 225

Falcon 2 140, 170, 195, 225, Tandem

Owner / Service Manual

April 2005 - Ninth Edition



Falcon 140, 170, 195, 225

Falcon 2 140, 170, 195, 225, Tandem

Copyright © 1994 through 2005 by Sport Kites, Inc. dba Wills Wing, Inc. All rights reserved.
No part of this manual may be reproduced in any form without the express written permission of
Sport Kites, Inc., dba Wills Wing, Inc.

April 2005 - Ninth Edition

500 West Blueridge Ave • Orange, CA • 92865 • Phone (714) 998-6359 • FAX (714) 998-0647
Internet Web address: <http://www.willswing.com> • E-mail: comments@willswing.com

Contents

Introduction	1
Disclaimer And Warning	2
Technical Information And Placarded Operating Limitations	3
A Note About Platform Towing	6
A Few Notes About The Falcon Tandem	7
A Note About High Duty Cycle Operations	8
A Note About Parts Replacement and Parts Interchangeability	8
Falcon Breakdown Procedure For Shipping And Reassembly Procedure	9
To break down the leading edges follow these steps	9
Remounting the rear leading edges	9
Falcon Set-Up Procedure	11
Laying the glider down flat	18
Setting the glider up flat on the ground	18
Launching And Flying The Falcon	19
Using Wing Tufts	19
Using wing tufts to find the minimum sink speed of your glider	20
Trimming Your Glider In Pitch	22
Speeds To Fly And Using Your Airspeed Indicator	24
Landing The Falcon	25
Falcon Breakdown	28
Falcon Stability Systems	30
Reflex bridle adjustment	30
Bridles too loose	31
Bridles too tight	31
Other factors of glider geometry which affect bridle adjustment and effectiveness	31
Maintenance Schedule	32
Every month or Every 30 flights	32
Every six months or Every 150 flights	32
Every twelve months or Every 300 flights	32
Special circumstances	32
A note about cables and cable maintenance:	33
Removing The Sail From The Airframe And Reinstalling	34
Sail removal	34
Reinstalling the sail on the frame	35
Tuning	36
Dismounting and remounting the sail at the tip	36
CG adjustment	36
Turn trim	36
Airframe	36
Battens	36
Sail mount plugs - adjusting sail tension and rotational alignment	36
Sail tension	37
Twisting a tip	37
Adjusting batten tension	38
Leading edge sail tension	39
Car Top Mounting And Transport	39
In Closing	39

Contents

Falcon HGMA Compliance Verification Specifications	40 - 48
Falcon Assembly Diagrams and Frame Plans	49
Falcon Round Control Bar	I
Falcon Streamline Control Bar	II
Falcon Noseplate Assembly	III
Falcon Rear Keel	IV
Falcon Kingpost Assembly	V
Falcon Crossbar Assembly	VI
Falcon Rear Leading Edge, Sail Adjuster, WO Tip	VII
Falcon 2 AT Round Control Bar	VIII
Falcon 2 AT Streamline Control Bar	IX
Falcon Tandem Control Bar	X
Falcon 2 Litestream Control Bar	XI
Falcon 2 Noseplate Assembly	XII
Falcon 2 Xbar Center	XIII
Falcon 2 Xbar LE Junction	XIV
Falcon 2 Rear Leading Edge Assembly	XV
Falcon 2 Kingpost Assembly	XVI
Falcon Tandem Tailboom Assembly	XVII
Falcon Control Bar Specifications	XVIII
Falcon 140 Frame Plans	XIX
Falcon 170 Frame Plans	XX
Falcon 195 Frame Plans	XXI
Falcon 225 Frame Plans	XXII
Falcon 2 140 Frame Plans	XXIII
Falcon 2 170 Frame Plans	XXIV
Falcon 2 195 Frame Plans	XXV
Falcon 2 225 Frame Plans	XXVI
Falcon Tandem Frame Plans	XXVII

Introduction

Thank you for purchasing a Wills Wing glider, and welcome to the world wide family of Wills Wing pilots. We are a company of pilots and aviation enthusiasts, and our goal is to serve your flying needs now and in the future, as we have done for pilots throughout the world since 1973.

We encourage you to read this manual thoroughly for information on the proper use and maintenance of your Wills Wing glider. If at any time you have questions about your glider, or about any aspect of hang gliding that your Wills Wing dealer cannot answer, please feel free to give us a call.

Please visit our web site at <http://www.willswing.com> on a regular basis. The site features extensive information about Wills Wing gliders and products, a Wills Wing Dealer directory, a comprehensive list of service and technical bulletins, current editions of owners manuals, our complete retail price list, a search engine, and more. Our web site is the means by which we will communicate with you when we have service advisories or other information related to your safety that we need to make you aware of.

We wish you a safe and enjoyable flying career, and, once again, welcome aboard!

Rob Kells, Mike Meier, Linda Meier, and Steve Pearson

Wills Wing, Inc.

Disclaimer And Warning

Hang gliding is a form of aviation. Like any form of aviation, its safe practice demands the consistent exercise of pilot skill, knowledge of airmanship and weather, judgment and attention at a level which is appropriate to the demands of each individual situation. Pilots who do not possess or exercise the required knowledge, skills and judgment are frequently injured and killed. The statistical rate at which fatalities occur in hang gliding is approximately one per thousand participants per year.

The Federal Aviation Administration does not require a pilot's license to operate a hang glider. Hang gliders and hang gliding equipment are not designed, manufactured, tested or certified to any state or federal government airworthiness standards or requirements. Hang Gliders are not required to be registered with the Federal government. As a result, we do not have a reliable way to keep track of contact information for the owners of Wills Wing hang gliders. It is your responsibility to check with us periodically for safety and airworthiness advisories and information related to your glider. The easiest way to do this is to check our web site at <http://www.willswing.com> Wills Wing hang gliding products are not covered by product liability insurance. You should never attempt to fly a hang glider without having received competent instruction. We recommend that you not participate in hang gliding unless you recognize and wish to personally assume the associated risks.

Please fly safely.

Wills Wing, Inc.

Technical Information And Placarded Operating Limitations

This manual covers the Falcon 140, Falcon 170, Falcon 195 and Falcon 225, all originally introduced in 1994 and 1995, (also to be referred to as "Falcon 1" models), as well as the Falcon 2 140, Falcon 2 170, Falcon 2 195, Falcon 2 225 and Falcon Tandem, all introduced in 2002.

Falcon 1 Models: The Falcon 140, 170, 195, and 225 have been tested and found to comply with the 1993 HGMA Airworthiness Standards. HGMA Certificates of compliance have been issued for these models on the following dates: Falcon 195 - August 10, 1994; Falcon 140, 170 and 225 - March 13, 1995.

Falcon 2 Models: The Falcon 2 140, Falcon 2 170, Falcon 2 195, Falcon 2 225, and Falcon Tandem have been tested and found to comply with the HGMA standards in effect as of 2002. HGMA Certificates of compliance were issued for these models on May 3rd, 2003.

The HGMA Certification standards require:

1. A positive load test at root stall angle of attack at a speed equal to at least the greatest of:
 - a. 141% of the placarded maximum maneuvering speed
 - b. 141% of the placarded maximum rough air speed
 - c. 123% of the placarded speed never to exceedfor at least three seconds without failure.

The required speed for all four sizes of the Falcon 1, for this test was 65 m.p.h.. For the Falcon 2 225, 56 mph, for the Falcon 2 140, 170, and 195, 59 mph, and for the Falcon Tandem, 61 mph.

2. A negative 30 degree angle of attack load test at a speed equal to at least the greatest of:
 - a. 100% of the placarded maximum maneuvering speed
 - b. 100% of the placarded maximum rough air speed
 - c. 87% of the placarded speed never to exceedfor at least 3 seconds without failure.

The required speed for all four sizes of the Falcon 1, for this test was 46 m.p.h.. For the Falcon 2 225, 40 mph, for the Falcon 2 140, 170, and 195 42 mph, and for the Falcon Tandem, 43 mph.

3. A negative 150 degree angle of attack load test at a speed equal to at least the greater of 30 mph or 50% of the required positive load test speed for at least 3 seconds without failure.

The required speed for all four sizes of the Falcon 1, for this test was 32 m.p.h.. For the Falcon 2 140, 170, 195 and 225, the required speed for this test was 30 mph, and for the Falcon Tandem, the required speed was 31 mph.

4. For all four sizes of the Falcon 1, with a Vne of 53 m.p.h., pitch tests at speeds of 20 m.p.h., 37 m.p.h. and 53 m.p.h. which show the glider to have a positive pitching moment coefficient over a range of angles of attack from trim angle to 20 degrees below zero lift angle at 20 m.p.h., and from trim angle to 10 degrees below zero lift angle at 37 m.p.h., and from 10 degrees above zero lift angle to zero lift angle at 53 m.p.h. For the Falcon 2 225, with a Vne of 46 mph, corresponding pitch tests at 20 mph, 33 mph and 46 mph, for the Falcon 2 140, 170, and 195, with a Vne of 48

m.p.h., corresponding pitch tests at speeds of 20 m.p.h., 34 m.p.h. and 48 m.p.h., and for the Falcon Tandem, with a Vne of 50 m.p.h., corresponding pitch tests at speeds of 20 m.p.h., 35 m.p.h. and 50 m.p.h.

5. Flight maneuvers which show the glider to be adequately stable and controllable throughout the normal range of operation.

The Falcons have been designed for foot launched soaring flight. They have not been designed to be motorized, tethered, or towed. They can be towed successfully using proper towing procedures. Pilots wishing to tow should be USHGA skill rated for towing, and should avail themselves of all available information on the most current proper and safe towing procedures. Suggested sources for towing information include the United States Hang Gliding Association and the manufacturer of the towing winch / or equipment being used. Wills Wing makes no warranty of the suitability of the glider for towing.

Flight operation of the Falcon should be limited to non aerobatic maneuvers; those in which the pitch angle will not exceed 30 degrees nose up or nose down from the horizon, and the bank angle will not exceed 60 degrees. The Falcon is generally resistant to spinning, but will spin from a stalled turn if the pilot applies positive pitch control aggressively in combination with roll control input so as to roll towards the high wing. Recovery from a spin requires unstalling of the wing, and it is therefore important that in the event of a spin, no application of nose up pitch control be held. The Falcon will recover from a spin once control pressures are relaxed. As the nose lowers and the angle of attack is reduced, the stall will be broken and the spin will stop. However, such recovery will consume significant altitude, and will result in the glider assuming an unpredictable heading. Recovery from a spin may therefore involve a flight trajectory which intersects the terrain at a high rate of speed. An aggravated spin could result in loss of control, in flight inversion, and structural failure. Therefore no attempt should ever be made to deliberately spin the glider.

The maximum steady state speed for a prone pilot in the middle of the recommended weight range full forward on the control bar is approximately 42 m.p.h. for the Falcon. The placarded speed never to exceed and maximum maneuvering speeds for the Falcons are:

<u>Model</u>	<u>Vne</u>	<u>Va</u>
All Falcon 1's	53 mph	46 mph
Falcon Tandem	50 mph	43 mph
Falcon 2 140, 170, 195	48 mph	42 mph
Falcon 2 225	46 mph	40 mph

The Falcon can be flown in steady state high speed flight with the pilot full forward over the bar without exceeding the VNE speed. Abrupt maneuvers may cause the glider to exceed VNE, and abrupt maneuvers should not be made from speeds above 46 mph, 43 mph or 42 m.p.h. depending on model.

The stability, controllability, and structural strength of a properly maintained Falcon have been determined to be adequate for safe operation when the glider is operated within all of the manufacturer specified limitations. No warranty of adequate stability, controllability, or structural strength is made or implied for operation outside of these limitations.

The stall speed of the Falcon at maximum recommended wing loading is 25 mph or less. The top (steady state) speed at minimum recommended wing loading for a prone pilot with a properly designed and adjusted harness is at least 35 mph.

All speeds given above are indicated airspeeds, for a properly calibrated airspeed indicator mounted in the vicinity of the pilot. Such an airspeed indicator is available through your Wills Wing dealer.

The recommended hook in pilot weight range for the Falcon 1 is:

Falcon 140:	120 - 210 lbs.	Falcon 170:	140 - 230 lbs.
Falcon 195:	150 - 275 lbs.	Falcon 225:	185 - 440 lbs.

The recommended hook in pilot weight range for the Falcon 2 is:

Falcon 2 140:	120 - 190 lbs.	Falcon 2 170:	140 - 220 lbs.
Falcon 2 195:	150 - 250 lbs.	Falcon 2 225:	185 - 300 lbs.

The recommended hook in pilot weight range for the Falcon Tandem is:

Falcon Tandem 185 - 500 lbs.

Be advised that pilots with hook in weights within 20 lbs of the minimum recommended will find the Falcon somewhat more demanding of pilot skill to fly, and that pilots with hook in weights of more than 130% of the minimum recommended will experience some relative degradation of optimum sink rate performance due to their higher wing loading. Please note that the term "recommended hook in pilot weight range" comes from the HGMA certification standards, and without some qualification, may be misleading. The recommended weight ranges as listed above represent the full range of pilot hook in weights over which the model listed will retain adequate stability, performance, control, and structural strength. A more appropriate term for the weight ranges listed above might be the "allowable" pilot hook in weight range. The pilot hook in weight ranges which we would actually "recommend" as being optimum are given in the following table:

The optimum hook in pilot weight range for the Falcon 1 is:

Falcon 140:	135 - 155 lbs.	Falcon 170:	155 - 190 lbs.
Falcon 195:	190 - 230 lbs.	Falcon 225:	230 - 300 lbs.

The optimum hook in pilot weight range for the Falcon 2 is:

Falcon 2 140:	135 - 165 lbs.	Falcon 2 170:	165 - 200 lbs.
Falcon 2 195:	200 - 240 lbs.	Falcon 2 225:	240 - 300 lbs.

The optimum hook in pilot weight range for the Falcon Tandem is:

Falcon Tandem 240 - 500 lbs.

The Falcon 2 models have superior aerodynamic performance to that of the corresponding Falcon 1 models, especially at the lower end of the speed range. On average, a given size Falcon 2 will have a 1-2 mph lower stall speed, with the same pilot weight, as the corresponding Falcon 1. This allows a heavier pilot to achieve the same, or better sink rate on the same size of the Falcon 2. At the same time, note that the Falcon 2 195 and 225 are built somewhat lighter, from a structural standpoint, than the corresponding Falcon 1's, and as a result do not have the same maximum allowable pilot hook in weights. Note in particular that while the Falcon 1 225 was considered suitable for light duty tandem flight, the Falcon 2 225 is NOT APPROVED for tandem flight under any circumstances.

A minimum USHGA Novice (II) level of pilot proficiency is required to fly the Falcon safely, unless under the direct supervision of a qualified instructor.

Operation of the glider by unqualified or under qualified pilots may be dangerous.

Operating the Falcon outside of the above limitations may result in injury and death. Flying the Falcon in the presence of strong or gusty winds, or turbulence may result in loss of control of the glider which may lead to injury and death. Do not fly in such conditions unless you realize and wish to personally assume the associated risks. Wills Wing is well aware that pilots have, and continue to perform maneuvers and fly in conditions which are outside the recommended operating limitations stated herein. Please be aware that the fact that some pilots have exceeded these limitations in the past without dangerous incident does not imply or insure that the limitations may be exceeded without risk. We do know that gliders which meet all current industry standards for airworthiness can and do suffer in flight structural failures, both as a result of turbulence, and as a result of various maneuvers outside the placarded operating limitations, including, but not necessarily limited to aerobatics. We do not know, and cannot know, the full range of maneuvers or conditions which may cause the pilot's safety to be compromised, nor can we test the glider in all possible circumstances.

A Note About Platform Towing

When platform towing, it is necessary to attach a nose line to the front of the glider, to restrain the glider at the proper pitch attitude while on the tow platform. If the noseline is installed improperly, it is possible for it to cause the bottom front wires to become detached from the nose of the glider as the glider departs the platform during launch, which will result in a complete loss of control of the glider and a very dangerous crash. Please see the diagrams below for the correct way and one incorrect way to install the nose line.

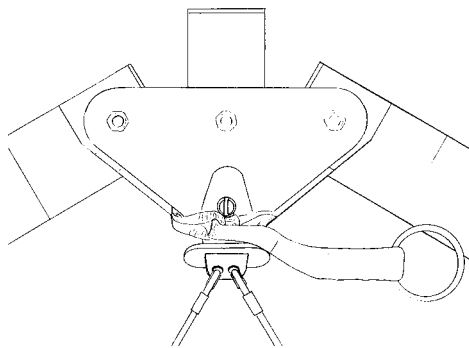

Correct Attachment

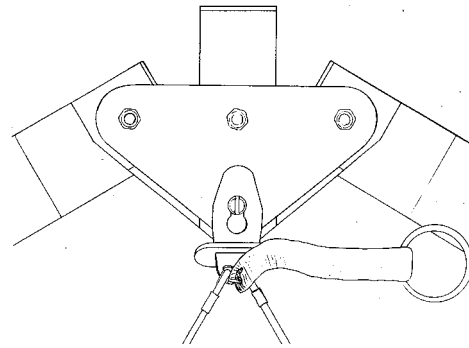

Incorrect Attachment - Unsafe!

When routed incorrectly, the nose line is simultaneously pulling down on the keel, and forward on the front wires and/or tang - which is exactly what is required to disengage the tang from the keyhole collar. In addition, because the nose line also normally pulls forward from the nose of the glider, it will normally restrain the front wires in approximately the normal position, until tension on the nose line is released upon launch from the platform. As a result, it may not be apparent that the front wires have become disconnected, or are in danger of being disconnected from the nose.

Please note that the nose line must not be routed in any way such that it can pull forward on the nose wires or the nose tang. The incorrect routing shown is one example of a way in which this could happen. It could also happen, however, if the nose line is routed outside the V of the wires, but behind the tang handle.

Please note that the keyhole safety anchor lock may be ineffective in preventing the nose wires from being disconnected by an improperly routed nose line. It may be possible during taxiing of the glider for the nose tang, by pivoting back and forth while pushing against the anchor lock, to rotate the safety anchor lock out of position.

All pilots planning to platform tow using a Wills Wing glider fitted with the keyhole tang nose catch must, as their last checklist item prior to "going to cruise," positively verify that the nose line is not routed in such a way that there is any possibility that it can cause the nose wires to disconnect.

A Few Notes About The Falcon Tandem

Federal Aviation Regulation FAR Part 103 - Ultralight Vehicles - which governs the flight operation of hang gliders in the United States - restricts the operation of any ultralight vehicle to a "single occupant." The United States Hang Gliding Association has obtained an exemption to the "single occupant" requirement of FAR Part 103 which allows for two place, or "tandem" flying in a hang glider. Pilots operating under this exemption must be individually authorized to do so by the exemption holder, and must operate under all of the requirements of the exemption in order to conduct legal two place flight operations. It is the pilot's responsibility to have the necessary skills, knowledge and experience, to obtain the proper authorization to operate under the exemption, and to operate under the requirements of the exemption. Tandem or two place hang glider flight requires special skills, experience and knowledge that are far beyond what is required for single place operations. Based on flight testing and other testing conducted by Wills Wing on the Falcon Tandem glider, we believe that the Falcon Tandem is suitable for two place flight, provided that the pilot in command has all the necessary knowledge, skills and experience to conduct such flight operations safely, and follows all appropriate procedures for safe two place flight. The Falcon Tandem model can also be flown single place by a pilot within the recommended weight range, and in the case of single place operation, a minimum USHGA Novice (II) level of pilot proficiency is required to fly the Falcon Tandem safely, unless under the direct supervision of a qualified instructor.

Falcon Tandems have been produced with two different control bar configurations. The first Falcon Tandems were built with "AT 68 plus four" control bars - the same control bar used on the Falcon 1 225. HOWEVER - to provide adequate structural margin for the Falcon Tandem, when equipped with this bar, the downtubes must be inner-sleeved. (AT 68 downtubes made with the Wills Wing conventional streamlined material do not normally have, or require inner sleeves.) The current standard and henceforth only available control bar configuration on all Falcon Tandems is the round 1.25" by .095" wall Tandem Control Bar.

Falcon Tandems have been produced with two different types of sail material in the trailing edge panel - 240 and Hydranet. The Hydranet sails use a slightly different batten profile in the two longest root battens - the #6 and #7, each of which has an increased amount of reflex. This is shown on the batten diagram. Hydranet cloth can be distinguished from 240 by the smaller size (about 3/16") of the squares formed by the reinforcing threads in the material.

A Note About High Duty Cycle Operations

Gliders which are used in a training environment, or in any situation which involves a high number of flight operations over short period of time, will require an accelerated maintenance program in order to maintain adequate airworthiness. The design and testing of these gliders does not necessarily take into account the types of wear which may result from high duty cycle operations. The operator must take responsibility to thoroughly and adequately inspect the glider to determine whether maintenance is being conducted on a schedule appropriate to maintain the airworthiness of the glider.

A Note About Parts Replacement and Parts Interchangeability

Falcon 1's and Falcon 2's share a number of parts, but many parts are different. In addition, there are configuration variations within both the Falcon 1 model line and the Falcon 2 model line. When ordering replacement parts, it is very important to provide the glider serial number to insure that the correct replacement parts are provided. The serial number is a five digit number, beginning with the number 2, and can normally be found in three places on the glider - written inside the nose of the sail (most reliable), on an adhesive label on the bottom of the keel at the nose, and written on the operating limitations placard on the bottom of the rear of the keel. Please also note that some configuration options - such as streamlined legs or a speedbar or folding speedbar basetube, may have changed since the glider was produced, so it is necessary to specify this information when ordering these parts.

Falcon Breakdown Procedure For Shipping And Reassembly Procedure

The Falcon can be broken down to approximately 2/3 of it's normal length by removal of the rear leading edges. The rear leading edge is slotted at its forward end, such that the slots engage around the clevis pin which is mounted in the forward section. (Note: Some of the following procedures do not apply to the Falcon Tandem. Due to a different leading edge construction, the Falcon Tandem must be disassembled at the crossbar leading edge junction in order to remove the rear leading edges. The alternate required procedures for the Falcon Tandem are included enclosed in parenthesis below.)

To break down the leading edges follow these steps

1. Lay the glider on the ground or floor, unzip and remove the bag and remove the Velcro ties. Undo the velcros which hold the sail around the sail mount plug and pull the sail rearward at each tip to dismount the sail from the rear leading edge. You may use a large, flat bladed screw driver to pry the sail mount webbing away from the slotted endcap. Take care that the screwdriver does not have a sharp edge which might cut or damage the webbing.
2. Obtain an indelible marker. Check to see if the rear leading edges are labeled left and right. If they are not, mark the rear leading edges left and right (remember that left and right are reversed if the glider is lying "on it's back", upside down. Push the sail up to where you have uncovered the point where the rear leading edge exits the front. Trace around the circumference of the 50 mm rear leading edge just aft of the 52 mm oversleeve so as to mark the point at which the rear leading edge is fully engaged in the front. (Not applicable on the Falcon Tandem.)
3. Scribe a line along the leading edge which crosses the front to rear leading edge junction. This will help to align the rear leading edge during reassembly. (Not applicable on the Falcon Tandem.)
4. Spray silicone spray lubricant on the rear leading edge at the point where it exits from the front.
5. Pull the rear leading edge straight aft to disengage it from the front. (On the Falcon Tandem, the breakdown point is forward of the crossbar junction. First disassemble the crossbar from the leading edge bracket by removing the safety ring, castle nut and bolt. Then remove the safety ring from the leading edge clevis pin located eight inches forward of the crossbar junction. Mark across the splice in the tubes located six inches forward of the crossbar junction to record the proper rotational alignment. Remove the clevis pin from the leading edge, and then pull the rear leading edge out of the front leading edge.) Put tape or otherwise protect the sharp edges of both the front and rear leading edge tubes from damaging the sail during transport..
6. Replace the sail mount ties, zip up the bag, and carefully fold the rear of the glider over against the front.

Remounting the rear leading edges

1. Make sure you are mounting the correct leading edge rear into the correct front (check the "right" / "left" designation).
2. Spray the forward six inches of the rear leading edge with silicone spray lubricant.
3. Slide the rear leading edge into the front, lining up the rotational alignment marks you made during breakdown, until the rear engages fully in the front leading edge, as indicated by the circumferential scribe made at the exit point of the rear leading edge during breakdown. (On the Falcon

tandem, re-install the clevis pin in the 3/16" hole located eight inches forward of the crossbar junction, and install the safety ring on the pin. Note that the pin is installed from the bottom of the leading edge, so that the safety ring is on the top of the leading edge.. Also, re-assemble the crossbar to the leading edge bracket. Refer to the diagram, and note that the bolt is installed from below, with the castle nut and safety ring installed on top of the crossbar. Note carefully the condition of the safety ring - if it is deformed such that the open end of the ring could catch on the sail, replace the ring with a new one. It is very important that the bolt be installed properly, with the nut and safety on top of the crossbar, and that the safety ring is not deformed. If this bolt is installed upside down, the ring could become caught on the sail and pulled out, which could allow the junction to come apart in flight. Make sure the top and bottom side wires are properly routed.)



4. Pull the sail down the leading edge.
5. Remount the sail to the rear leading edge, making sure to align the inner sail mount webbing squarely in the slot and attach the securing velcros.

You may find it helpful to use a large, flat bladed screw driver to pry the sail mount webbing over the end of the leading edge tube and into the slot. Take care not to damage the webbing. Alternately, first remove the sail mount screws located at the front of each leading edges to release the tension. The sail mount screws may be difficult to replace until after the glider is completely assembled. Spread the wings carefully and incrementally while pulling the sail forward at the nose during assembly to prevent damage to the sail.

Falcon Set-Up Procedure

The Falcon has been specially designed to set up quickly and easily either on the control bar or flat on the ground. We will first cover the steps for setting up on the control bar.



1. With the glider in the bag, lay the glider on the ground, zipper up, with the nose into the wind. If there is more than five mph of wind, or if the wind is gusty, turn the glider 90 degrees to the wind direction.
2. Undo the zipper, remove the battens, remove the protective pad at the rear wire station on the keel, and remove the control bar bag.
3. Separate the control bar legs.
 - a. If the glider is equipped with a folding basetube:
 - i. Straighten the fold in the folding basetube.
 - ii. Preflight the folding basetube center hardware at this time, checking that the nuts and coil spring pins are secure, and that the tangs are straight and in good condition.
 - iii. Slide the basetube center sleeve over the center joint until it is positioned between the button spring pins. (Note: If you plan to clamp instruments to the basetube center, position the center sleeve so that one button passes through the hole near one end of the sleeve to prevent it from rotating.

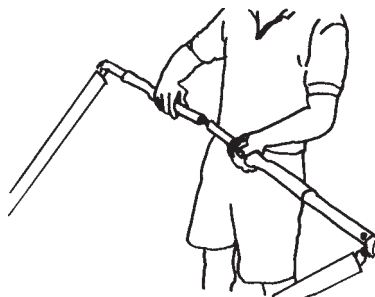

- b. If the glider is equipped with a non folding basetube:
 - i. Remove the safety ring, nut and bolt from the corner bracket.
 - ii. Insert the corner bracket all the way into (or onto for the Falcon Tandem) the basetube.
 - iii. Install the bolt, nut and safety, securing the bracket to the basetube.

Make sure that the aluminum fitting is fully inserted into (or, in the case of the Falcon Tandem, over) the basetube, and that the bolt is through both the basetube and the fitting. If the hole in the fitting is outside the end of the basetube, the fitting is not fully installed, and will likely disengage in flight resulting in a dangerous structural collapse and loss of control of the glider.

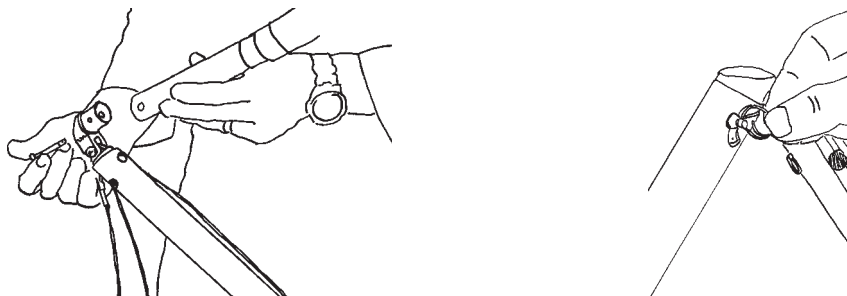

Do not insert the fitting at an angle, and do not force the fitting into the basetube if it does not slide in freely. Check for dirt or damage to the fitting or the inside of the basetube. If the fitting is forced into the basetube, it may be impossible to remove. See your dealer if the fitting becomes difficult to install or remove.

4. Flip the glider upright and set it on the control bar, and remove the glider bag and all Velcro sail ties.

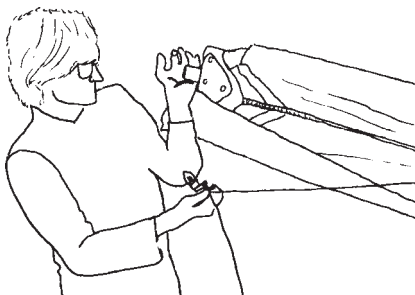

5. Spread the wings almost all the way. If you have left the bridles attached, this will automatically stand the kingpost upright. If not, lift gently on the top side wire as you spread the second wing, (do not pull the wire to the side) and the kingpost will stand up.

It is possible, especially on the Falcon Tandem, for the kingpost top to drop down to one side of the keel and become wedged behind the crossbar. If you feel ANY resistance as you spread the wings, stop and find out what is causing it.

6. If the bridles have been detached, attach the bridle ring to the snap hook at this time, taking care that there is not a twist or rotation in the bridle ring which causes the bridle lines to cross over one another.

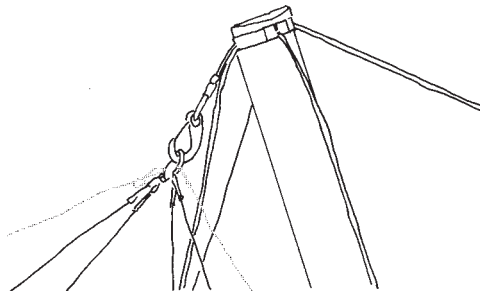

7. Lay out the battens and check each batten for symmetry against the corresponding batten from the other wing. Wills Wing convention is that *black tipped battens go in the right wing and white tipped battens in the left*, except for the straight #1 plug-on battens both have black tips.

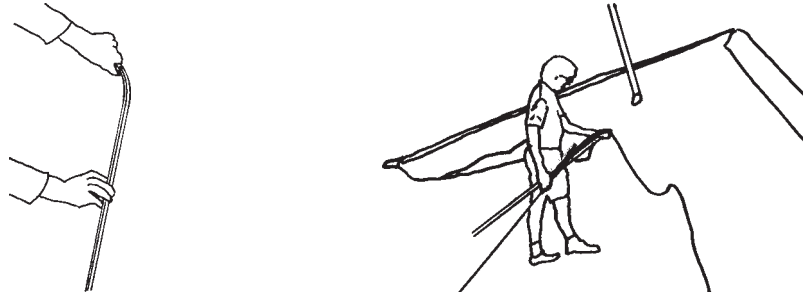

8. Install the 3 longest cambered top surface battens in the sail. Each batten is secured by a double loop of the batten string (double purchase) on Falcon 1's, and by a spring batten tip inserted into the trailing edge hem on Falcon 2's and the Falcon Tandem. To engage the spring batten tips in the trailing edge of the Falcon 2, push the plastic tip into the batten while pulling back on the trailing edge of the sail, until you can slide the end of the plastic tip into the open portion of the trailing edge hem. (We recommend you use the batten installation tool (6" length of 3/4" aluminum tubing, provided with your Falcon 2 or Falcon Tandem), instead of your thumb to push on the lower portion of the end of the batten tip to compress the tip into the batten during installation. The spring tension is high enough that repeatedly pushing the batten tips in with your thumb may result in injury.) Order of batten insertion is longest to shortest, from the root out. Spread the wings all the way and check all cables for any twisted thimbles or tangled cables.

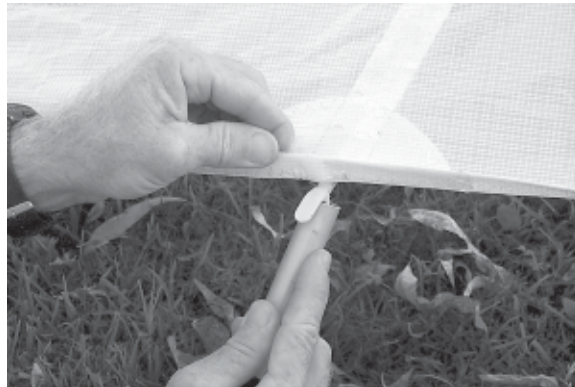

9. At the rear of the keel, tension the crossbar by pulling on the rope loop which is attached to the sweep wire keyhole channel or keyhole tang. Drop the keyhole channel all the way down over the top portion of the keyhole collar, and let it slide forward into the locked position. (On the 225 and Falcon Tandem, the xbar sweep wire and top rear wire are separate, and each has a keyhole tang. The sweep wire is attached first, and the top rear wire second - both to the same bolt. After

installing the top rear wire, be sure to install the rubber safety to hold the tang in position on the collar.)

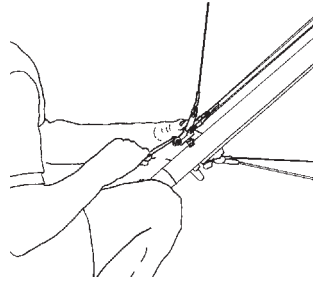

Never install the keyhole channel or keyhole tangs onto the keyhole collar without making absolutely sure that they are fully engaged on the narrow neck of the collar and slid forward into the fully locked position. An in-flight disengagement of this attachment will cause a complete loss of structural support of the glider and a total loss of control.

10. Remove the tip cover bags, and install the remaining cambered battens.
11. Install the straight plug-on #1 battens. Insert one end of the batten through the gap in the stitching in the bottom surface seam. This end plugs onto the stud on top of the leading edge, and the batten string is secured double purchase to the other end.

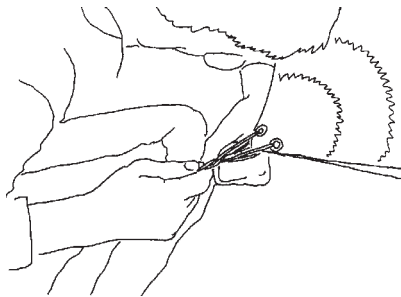

Also install the washout tips, by plugging them straight into the receptacles in the back side of the leading edge tube. Make sure they are inserted as far as they will go, and then rotate them until the spring loaded button snaps into the detent inside the receptacle. Note: On Falcons produced after August of 2002, the button spring retention system on the washout tubes has been replaced by a bungee retention system. This provides a more positive retention of the washout tube in the leading edge - especially in applications such as aerotowing, where the vibration of taxiing on the cart may otherwise cause the washout tubes to become disengaged. If you aerotow, we recommend that you retro-fit your washout tubes with the bungee retention system.)

12. At this time preflight the following from the open end of the wingtip:
 - a. The sail mount webbing - make sure that the inner loop of webbing is laying flat in the bottom of the slot in the sail mount endcap.
 - b. The number one batten clevis pin and safety.

13. Go to the nose and attach the keyhole tang securing the bottom front wires, by pulling down on the nose of the glider while pressing the tang upwards over the shouldered bolt. (Remember it is the pulling down of the glider's nose rather than the upward pressure on the tang that allows you to install the tang over the bolt. If you have difficulty installing the tang, and no wires are twisted or thimbles cocked, it is probably because the glider is not sitting on level ground.)

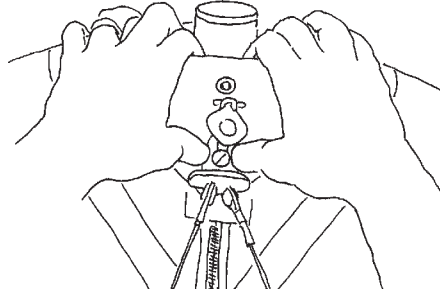

14. Secure the aluminum safety lock by rotating the lock into position such that the tang is prevented from sliding forward and disengaging from the bolt.

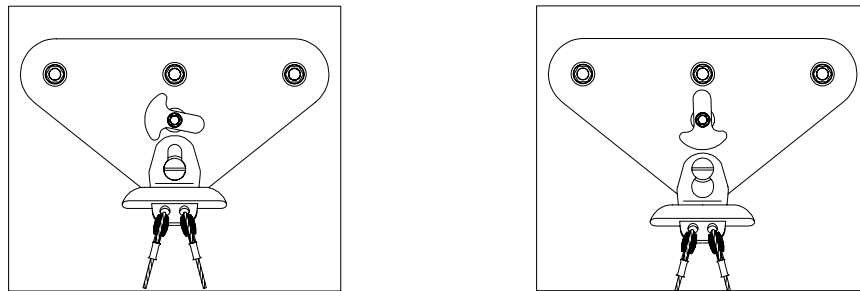

Most Falcon 2s have a spring loaded button-lock that replaces the safety lock assembly shown above and automatically engages as the keyhole tang slides into the annular groove in the keyhole bolt collar. This assembly is illustrated in the Falcon 2 Noseplate diagram at the back of this manual.

15. Push the nose batten fully back into the sail so that the tip rests on top of the keel. Look into the noseplate and preflight the top front wire. Preflight each of the lockuts on the bottom of the noseplate - make sure they are tight, and that the bolt extends at least one full thread beyond the nut.

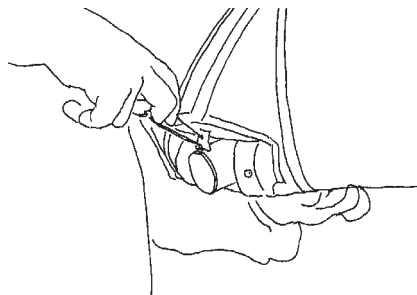

16. Conduct a complete preflight of the glider, checking all assemblies which have not already been checked. Every bolt, nut, pin, safety ring, and fastener of any kind should be checked during every pre-flight. A full pre-flight inspection should precede every flight you make, not just the first flight of the day.

Along the left leading edge

While pushing up on the leading edge between the nose and the crossbar junction, step on the bottom side wire with about 75 lbs. of force. This is a rough field test of the structural security of the side wire loop, the control bar, the kingpost, and the crossbar, and will likely reveal a major structural defect that could cause an in-flight failure in normal operation.

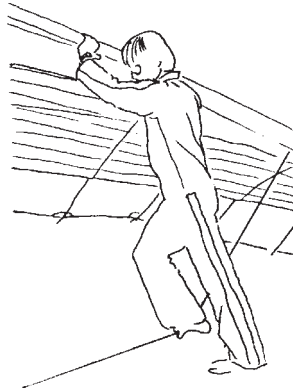

Check the nut which secures the leading edge crossbar bracket to the leading edge, and check the nut and safety ring which secures the crossbar to the bracket. Check that the sail is not caught on the crossbar end, nor on the safety ring, nor on any of the hardware.

At the left wingtip

Check the proper installation of the number one batten, and the sail mount webbing.

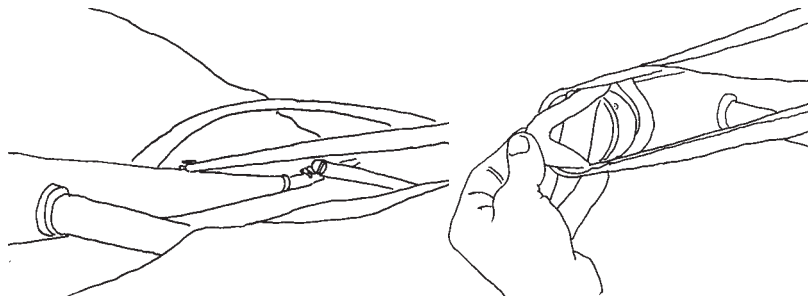

Along the trailing edge, left wing

Check that there are no tears in the sail material along the trailing edge.

Check that all batten strings are properly secured or that the spring batten tips are properly engaged in the trailing edge hem.

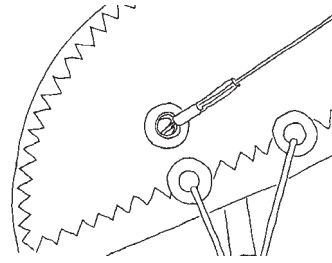
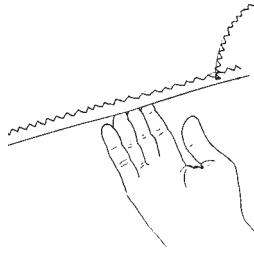

Check that the bridles are properly engaged, with the plastic retainer balls fully seated against the grommet, and that no bridle cable is hooked underneath a more inboard batten.

Wrong!

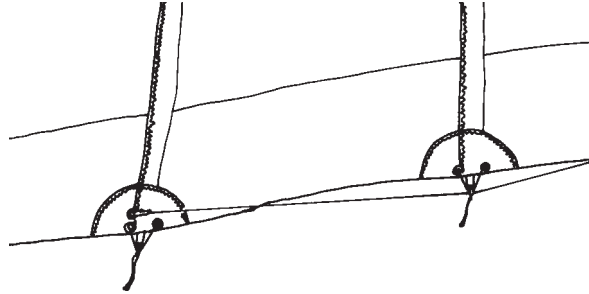

From the rear keel

Check the nut on the top of the kingpost base bracket which secures the bracket to the keel.

Check the nut & bolt, or the 1/4" rivet which secures the kingpost to the bracket..

Check the condition of the sweep wires in the vicinity of the kingpost base bracket.

Check the kingpost top for proper attachment of the bridles and condition of the top rear wire and bridle pigtail wire.

Check again that the keyhole channel is fully engaged and locked to the keyhole collar.

Along the trailing edge, right wing

Same as for left wing.

At the right tip

Same as for left tip.

Along the right leading edge

Same as for left leading edge.

Under the glider, at the control bar

Sight down the downtubes, making sure that they are straight.

Check the cables at the control bar corners, making sure there are no kinks or twisted thimbles. Check for proper installation of all nuts and safety rings at the control bar corners.

Check the control bar apex bracket hardware, including the clevis pin safeties, the control bar top plug bolts and nuts, and the elbow to apex bracket clevis and safety or nut and bolt.

Check the main and backup hang loops, that they are properly installed in the proper position and that they are in good condition.

Check the attachment of the sweep wire to the crossbar, and the center hinge pin or bolt.

At the nose

Check the security of all nuts at the noseplate, and check the top front wire. Check that the keyhole tang safety is properly secured.

Laying the glider down flat

Once the glider is assembled it can easily be laid down flat on the ground.

1. Pivot the keyhole anchor safety and release the bottom front wires from the noseplate.
2. Rock the glider forward so that the basetube folds rearward and underneath the glider as you gently lower the glider to the ground.

Reverse the procedure to set the glider upright again.

Setting the glider up flat on the ground

In areas where the ground is not rocky and when there are strong winds, you may wish to set up the glider flat on the ground. This is easy to do, and relatively few parts of the set up procedure are different from what has been described.

1. After unfolding and securing the control bar, flip the glider over right side up with the control bar still flat under the glider.
2. Spread the wings and install all the battens. (Note: Perform all the normal preflight operations as described above).
3. Tension the crossbar. (Note: while the 140 Falcon can be laid flat after set-up, the tension in the side wires is high in the laid flat configuration, and this precludes tensioning the glider with the glider laid flat on the ground.)
4. When ready, raise the nose of the glider while pulling on the bottom front wires to raise the glider up onto the control bar. Secure the bottom front wires as described above.

Launching And Flying The Falcon

1. If the wind is more than 10 mph or gusty you should have an assistant on your nose wires on launch, and, if necessary, an assistant on one or both side wires. Make sure all signals are clearly understood. Do a hang check immediately prior to launch. The angle at which you hold the glider should depend on the wind speed and slope of the terrain at launch; you want to achieve a slight positive angle of attack at the start of your run.
2. Run aggressively on launch and ease the bar out for lift off.
3. The flying characteristics of the Falcon are typical of a medium performance flex wing. Make your first flights from a familiar site in mellow conditions to give you time to become accustomed to the glider.
4. We recommend that you hang as close as possible to the basetube in the glider - this will give you lighter control pressures and better control.

Using Wing Tufts

Your Wills Wing glider has been equipped from the factory with short yarn tufts on the top surface of each wing. The shadow of these tufts will be visible through the sail. The tufts are useful for indicating the local reversal of the airflow which is associated with the onset of the stall in that portion of the wing. You can use these tufts, as described below, to help determine when you are flying at minimum sink airspeed.

There are two important airspeeds with which all hang glider pilots should be intimately familiar; minimum sink airspeed (hereinafter referred to as VMS) and minimum controllable airspeed (MCA). The most important of these two is MCA. Minimum sink airspeed is that speed at which your descent rate is the slowest possible. It is the speed to fly when you want to maximize your climb rate in lift, or slow your rate of descent to a minimum in non lifting air. (You would normally not fly at VMS in sinking air; the strategy there is normally to speed up and fly quickly out of the sink. By minimizing your time spent in the sinking air you minimize altitude lost, even though you have momentarily increased your sink rate by speeding up.)

Minimum controllable airspeed is that speed below which you begin to rapidly lose effective lateral control of the glider. Recognition of this speed and its implications is a more subtle problem than many pilots realize. We have seen several instances of pilots who were having a lot of trouble flying their gliders simply because they were unknowingly trying to fly them too slowly; below the speed at which the glider responded effectively to lateral control inputs. It is our opinion that a great percentage of hang gliding accidents are caused by inadvertent flight below MCA, and subsequent loss of control of the glider with impact preceding recovery. Such incidents are usually attributed to “stalls,” but it is not the stall per se that causes the problem, indeed the glider need not even be “stalled” in the traditional sense.

There is no necessary cause and effect relationship between minimum sink speed and minimum controllable airspeed. VMS is determined primarily by the wing loading and span loading, the wing planform, the wing section characteristics, etc. MCA is influenced most heavily by the tension in the sail; how much “billow” the glider has. However, in your Wills Wing glider, as in most hang gliders, MCA and VMS evolved towards a common value during the design and development of the glider.

This is so because if the wing is tuned so tight that minimum controllable airspeed is at a higher speed than minimum sink speed, then effective sink rate performance can be improved by loosening the wing so as to lower the minimum controllable airspeed. Conversely, if minimum controllable airspeed is reached at a speed below that of minimum sink, the wing can usually be tightened so as to improve glide performance without significant sacrifice in other areas.

Using wing tufts to find the minimum sink speed of your glider

On a flex wing hang glider, the wing experiences a gradual and progressive stall, and different spanwise stations of the wing stall at different angles of attack. Contrary to popular belief, a hang glider wing usually does not stall first in the root or center section. It is true that because of wing twist the root section is at the highest angle of attack relative to the remote free stream airflow, but other factors influence the stall propagation on the wing. Specifically, a flex wing hang glider usually stalls first somewhere outboard of the root on each wing, approximately one fifth to one third of the way out from the root to the tip, in the area where your tufts are located. As the angle of attack is raised further, the stall propagates both outward towards the tips and inward towards the root. If you wish to observe the stall propagation across the whole wing on your glider, you can cut some more tufts from knitting yarn, about 3-4" long, and tape these to the top surface of your sail across the rest of the span.

During normal flight the flow will be chordwise along the wing, and the tufts will point towards the trailing edge. When the wing stalls, the tufts will reverse direction, indicating the local flow towards the leading edge.

At the first onset of stall, the tufts will indicate the impending separation by first wiggling, and then deflecting spanwise, before they fully reverse and point forward. The first onset of stall occurs well before the familiar “stall break” in which the glider pitches uncontrollably nose down to recover from the stall. By the time the stall break occurs, all tufts but those farthest outboard and those farthest inboard will have indicated reversed flow.

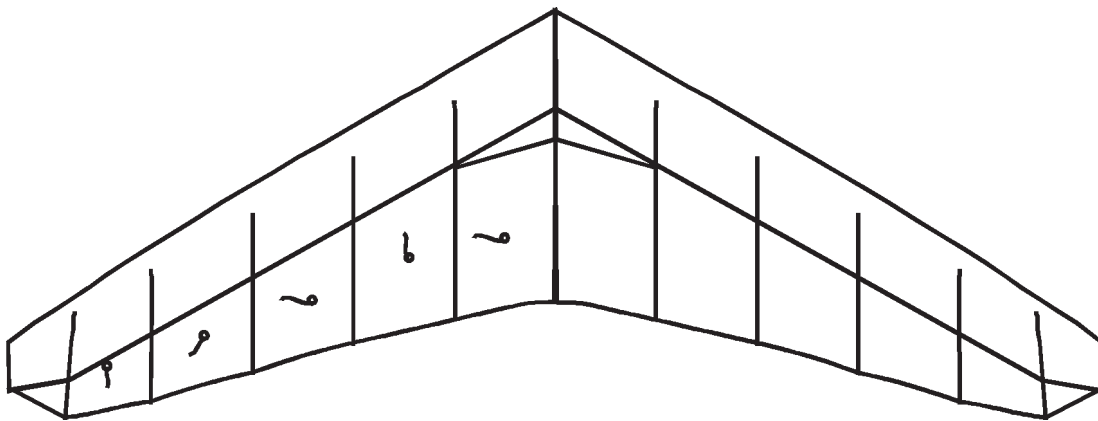

The first onset of midspan stall as indicated by the first tickling of the tufts indicates that you have reached the angle of attack corresponding to the glider's minimum sink airspeed. This will also be very close to the glider's minimum controllable airspeed. To find the glider's minimum sink speed, fly the glider in smooth air, early in the morning or late in the afternoon. When you are well away from the terrain, and well clear of other aircraft, look up at the wing tufts while you very gradually

reduce the speed of the glider. Note the speed at which the first tuft first begins to wiggle just prior to blowing spanwise toward the tip. (If the tufts contain static electricity, they may not show this lateral wiggle prior to reversal. However, you may get other clues to the beginning of separation, such as slight flutter or rumble in the top surface of the sail.) This is your speed for minimum sink rate. Familiarize yourself with the position of the control bar relative to your body at this speed, with the sound and feel of the wind, with the reading on your airspeed indicator, and with the feel of the glider in terms of pitch and roll pressures. Most of the time when you are flying it will not be practical to look up for extended periods of time at your tufts. That is why familiarization with these other, more accessible indicators is important.

After finding your minimum sink speed, experiment with roll control response at speeds just above and just below this speed to find the value of MCA and the corresponding bar position and other indicators for this speed. Realize that your effective MCA is going to be higher and higher as the air becomes more and more turbulent; control response that is perfectly adequate in smooth air will not be good enough in rougher air. Try flying the glider with the midspan tufts fully reversed; you will probably find that the glider is somewhat controllable, but only with a lot of physical effort. Note that both MCA and VMS come well before the glider actually “stalls” in the traditional sense, i.e. pitches uncontrollably nose down. You may also be able to sense, or your vario may tell you that although the glider has not “stalled” (pitched nose down) your sink rate has increased significantly. In this mode the glider is “mushing.”

Once you have familiarized yourself with the glider’s characteristics in this range of speeds, you will not need to look at the tufts very often. You will know from bar position and bar pressure, and from the sound and feel of the relative wind when you are at your minimum sink / minimum controllable airspeed. In general, you should not fly your glider below this speed. Be aware, however, that when you are flying at minimum sink in thermal gusts and turbulence, you will experience gust induced separation of the airflow which will periodically cause the tufts on your sail to reverse.

Of course in a turn, your minimum sink *speed* goes up because you are banked, and the bank effectively increases your wing loading which increases your flying *speed* for any angle of attack. But note this: *The tufts indicate angle of attack, without regard to airspeed!* Therefore, if you practice flying various bank angles in smooth air (while well away from any terrain or other gliders) and watch your tufts (on the inside wing, which will be at the highest angle of attack) you will get a feel for the way your minimum sink speed varies at varying bank angles.

One final caution: from time to time a tuft may stick completely to the sail, and fail to properly indicate the direction of local flow. This may result from static buildup, or from the fine threads of the yard becoming caught on a seam or some dirt or imperfection in the sail. The tuft may stick while indicating normal flow, but most often it will stick after having reversed, such that the tuft will indicate a stalled condition that does not exist. One clue in this situation is to note whether or not the tuft is wiggling. Since flow reversal occurs during a turbulent separated flow, a reversed tuft should be wiggling rapidly. If it is not, it is probably stuck. A tuft indicating normal flow will not usually wiggle. An occasional application of silicone spray to the tufts, and making sure that they are positioned so that they cannot catch on any seam will minimize the problem of sticking.

Trimming Your Glider In Pitch

The fore and aft location along the keel of your hang point is commonly (if mistakenly) referred to as your “CG location.” The location of this hang point will, all other things being equal, determine at what angle of attack and airspeed your glider will naturally tend to fly (or trim), and therefore how much bar pressure there is to pull in from trim to a given faster speed, or how much pressure there is to push out from trim to a given slower speed. The farther forward your hang point is, the faster the glider will trim, the less effort will be required to fly fast, and the more effort will be required to fly slow. Since the Falcon performs best at speeds relatively close to VMS, it is usually best to trim the glider at between minimum sink airspeed and perhaps 3 mph above that. Hang loop fore and aft position is adjusted by loosening the Velcro cinch strap on the main hang loop, repositioning the loop as desired, and retightening the cinch strap. This strap must be very tight to insure that the hang strap does not move during set up and breakdown, or in flight. To tighten the Velcro, grasp the hanging portion of the hang strap with your left hand and pull down while pushing up with your left thumb on the Velcro cinch strap where it passes through the top end of the hang loop. At the same time, pull up vigorously on the cinch strap and press it into place against the mating Velcro surface.

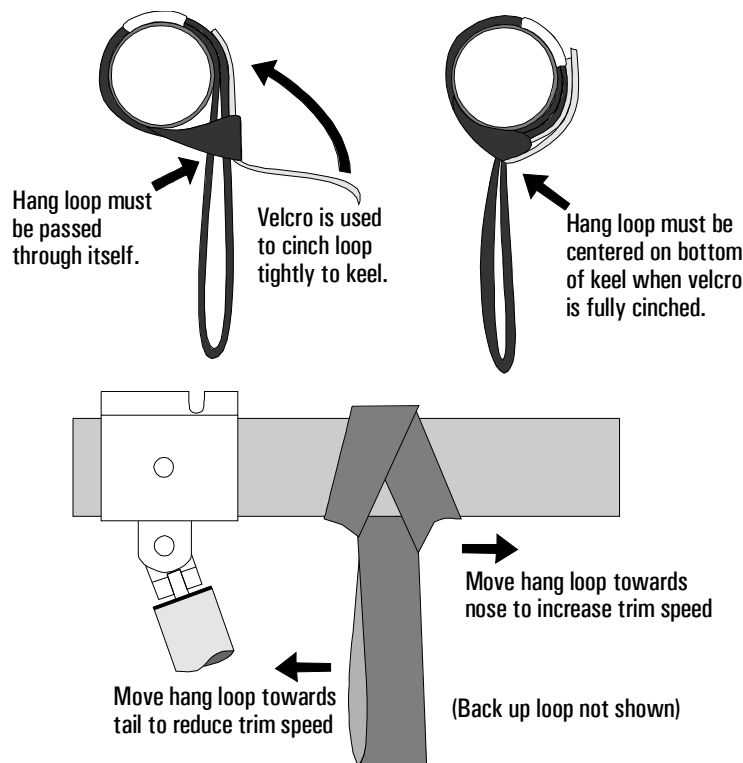

We recommend that you not stow your glider bag, or any other cargo on the glider. The practice of attaching your glider bag to the keel, for example, can drastically alter the pitch trim and static balance of your glider, and adversely affect its flying and landing characteristics. The best place to carry your glider bag or other cargo is in your harness.

In the absence of the use of tufts, it has become common for pilots to talk about bar position, or about indicated airspeed, when trying to communicate how to trim a glider properly or how to fly a glider at the proper speed for a given situation. The problem is that these methods are unreliable and inconsistent from one pilot to another even on the same glider. The angle at which your harness suspends your body in your glider has a great deal to do with your perception of the bar “position” relative to your body. Airspeed indicators vary in their indicated airspeed depending on the make of the instrument, its calibration, any installation error, etc. The use of tufts gives you an absolute first hand indication of the actual aerodynamic event associated with two critically important airspeeds on your glider. It is a potentially useful tool that may improve your flying.

Speeds To Fly And Using Your Airspeed Indicator

The optional Wills Wing Hall Airspeed Indicator has been specially designed to help you fly your Falcon at the proper speeds for optimum safety and performance.

There are four color coded bands on the ASI:

White: This is the range from 20 mph to 30 mph. This is the normal flying speed range. While thermalling or climbing flying in lift, try to keep your speed within the lower half of this range. For gliding in light sink or light headwind, you will want to fly in the upper half of this range.

Green: The top of the green region represents the placarded maximum rough air and maximum maneuvering speeds. This speed of 46 mph (42 mph on the Falcon 2's) should not be exceeded except in smooth air, and no abrupt large control deflections should be used above this speed. In heavy sink or strong headwinds it is recommended that you keep the airspeed “in the green” for best penetration and glide ratio over the ground.

Yellow: This region represents the upper speed range between maximum rough air / maximum maneuvering speed and the speed never to exceed. You should fly in this range only in smooth air as described above.

Red Line: This is your never to exceed speed. *At no time should you fly faster than this speed.*

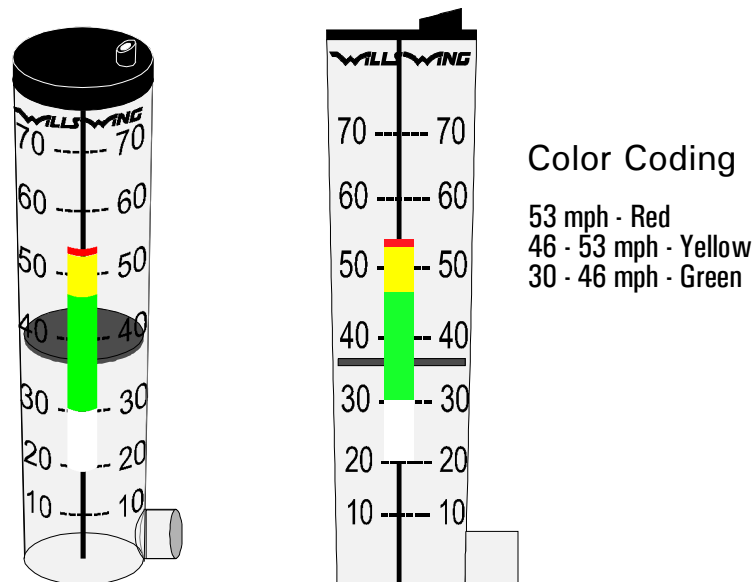

The design of the Hall type airspeed indicator involves using a ram air versus static pressure differential to raise a disc in a tapered tube against the force of the weight of the disc. Because of this, the ASI has the following operating limitations:

- a. It is only accurate in one G flight. If you are turning at a bank angle of more than 30 degrees, the ASI will read artificially low as a result of the G loading of the turn. Reliance on the ASI for limiting airspeeds in high banked sustained spiral maneuvers will likely cause you to exceed the placarded speed limitations of the glider and will compromise your safety.
- b. It is only accurate when within 15-20 degrees of the vertical orientation.

Landing The Falcon

We recommend using an aircraft landing approach (45 entry leg, downwind leg, base leg, and final leg) whenever possible, and we suggest that you practice making your approaches with as much precision as possible. Under ideal conditions, landing approaches are best done so as to include a long straight final into the wind at a speed above best L/D speed. In a very limited field, or a field which slopes slightly downhill, when landing in light wind, you may need to make your final approach at a slower speed, perhaps as slow as minimum sink, in order to be able to land within the field. In winds of less than 5 mph, if the slope is steeper than 12:1, you should seriously consider landing downwind, uphill; or crosswind, across the slope. Landing attempts which require slow speed approaches, maneuvering around obstacles or into a restricted area, or downwind or crosswind landings are not recommended for pilots below an advanced skill level.

Standard Aircraft Approach Pattern

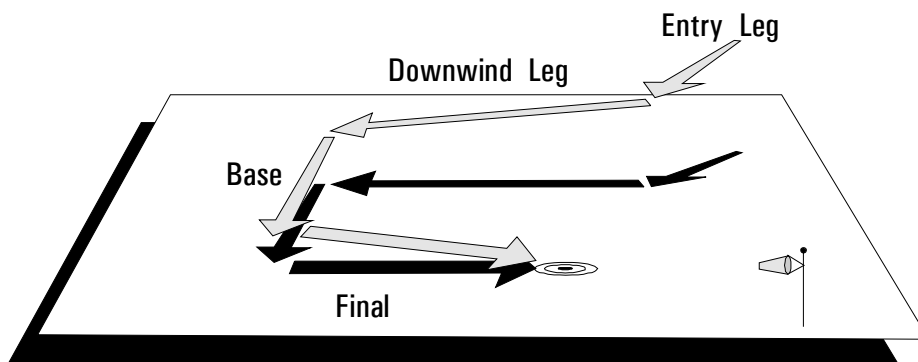

The best way to avoid roll / yaw oscillations on approach is to fly your entire approach at a constant airspeed, and to control your touchdown point by making adjustments to the shape of your pattern. In particular, we recommend against the technique of making a diving turn onto final. This maneuver, sometimes called a “slipping turn” is often taught to student hang glider pilots as a way to lose altitude during the approach. While it will work reasonably well with low or medium performance low aspect ratio gliders which have high levels of yaw stability and damping, and which are able to lose energy by diving because of the large increase in drag at higher speeds, on a high performance glider this technique serves only to convert the energy of altitude to energy of speed, while at the same time suddenly increasing the glider’s sensitivity to control inputs. The result is a high probability of overshooting the intended landing point and the prospect of roll / yaw oscillations which may interfere with a proper landing. If you develop good habits and the skills to fly precise approaches now, it will make your transition to higher performance gliders easier later on.

Once established on a straight final approach, with wings level and flying directly into the wind, you should fly the glider down to where the basket is between three and six feet off the ground. At this altitude, let the control bar out just enough “round out” so that your descent is arrested and your flight path parallels the ground. The remainder of your approach will consist of bleeding off excess speed while paralleling the ground and keeping the wings level and the nose into the wind until it is time to “flare” for landing.

Prior to the landing flare your body position should be generally upright, but slightly inclined forward, with your head and shoulders forward of your hips and your legs and feet trailing slightly behind.

Your hands should be at shoulder width and shoulder height on the uprights. You should be relaxed, with a light grip on the bar, and your weight should be fully supported in your harness and not at all by your arms. There are several options for when to make the transition from prone to this upright position. Some pilots favor going upright with both hands moving to the downtubes while still at altitude prior to the start of the approach. Others transition at the start of the approach to a semi upright position with one hand on a downtube and one hand on the basetube, and complete the transition by moving the other hand to the downtube just a few seconds prior to flare. Still others fly with both hands on the basetube until established on final glide, and then transition one hand at a time to the downtubes prior to flare.

Whichever method you use, there are a few important principles to observe. The first is that you should not make any change in hand position unless you are flying at or very near trim speed. At speeds faster than trim, you will be holding the bar in in pitch against substantial force, and if you let go to move your hand the glider will pitch up and roll towards your remaining hand. The second is that while moving either hand, you have no control over the glider. You should move only one hand at a time. Even so, if you can't make the transition in the position of each hand quickly and reliably, you should transition both hands while at altitude, before you start your approach. Otherwise, if you fail to make a quick transition, you could be out of control close to the ground, and suffer a turbulence induced change in heading or attitude without sufficient time to recover. Many pilots make the mistake of trying to change position while flying fast and close to the ground, and experience a dangerous loss of control as a result. A third principle to observe is that if you are using a "pod" type harness, you should unzip and confirm that your legs are free to exit the harness at least 500 feet above the ground and before you start your approach. If there is any problem finding the zipper pull, or dealing with a stuck zipper, you don't want to have to try to fix that problem while also flying the approach.

Once established on a wings level short final, into the wind, body upright and with both hands on the downtubes, your final concern is the timing and execution of the landing flare. The goal is to arrive on the ground, on your feet, under control with the glider settling on your shoulders. If the wind is 15 mph or more, you will not really execute a flare at all; you will simply slow to minimum flying speed, put a foot down, and step onto the ground. In lighter winds, you will want to use some combination of a final nose up flare, and running out your landing, in order to finish the flight on your feet with the glider settling on your shoulders. The lighter the wind, the stronger should be both your flare and your run.

The traditional method of landing in light or no wind calls for a sharp, aggressive flare at precisely the correct moment. This technique works fine when done correctly, but it's not easy to get the timing just right. Flare too early and you will climb, and then fall with the nose pitching down. Flare too late and you won't get the nose up enough to stop your forward motion, and the glider may nose into the ground as you run into it from behind.

The flare timing process is made much easier by using a combination of a "crescendo flare" and a run out of the landing. As you bleed off speed on final, flying just above the ground, you are at first letting the control bar out towards its trim position. As the glider reaches trim speed, which will normally be one to three mph above stall speed, you begin to gently push the bar out to keep the glider from settling. At this point it is almost time to flare. As the glider enters the "mushing" range of angles of attack, it will begin to settle in spite of your continuing to ease the bar out. This should be happening well before your arms are significantly extended. At this point begin your flare by smoothly accelerating the rate at which you push out on the bar. At the same time, draw one leg

forward, put a foot down, and start to run as hard as you can. This run should be very much like an aggressive take off run – your body should be leaning forward into the run and you should be driving with your legs. The difference here is that while you are leaning into your run and driving forward with your legs, your arms are extending fully from your shoulders, pushing out, and what feels like upwards, on the control bar in an accelerating, “crescendo” flare.

Done correctly, this type of flare / run combination will bring the glider quickly to a very nose high attitude, producing a great deal of drag and quickly arresting all of your forward motion. You will feel the glider pulling you from behind, resisting your attempt to run, and as you slow down the glider will settle gently on your shoulders. Even in no wind, you should not have to take more than a few steps. If your timing is a little early, and you feel the glider start to climb, simply stop pushing out and resume the flare when the glider again begins to settle. If your timing is a little late, your feet will touch down a little sooner, but as long as you’re running and flaring at the same time, the glider will stay over your head or behind you.

Note: Landing in a significant wind does not require a substantial landing flare; the pilot merely slows to near zero ground speed and touches down. The proper flare in light or no wind conditions is a dynamic action which causes a sudden and severe pitch up rotation of the glider. Pilots who have trouble with the flare, and with the glider nosing over during landing, usually do so because of one of the following problems:

- a. Harness leg straps too long / hanging too low below the glider, and / or hands too low on the control bar. This reduces pitch authority and prevents an adequate flare.

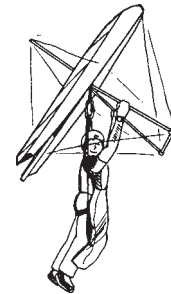
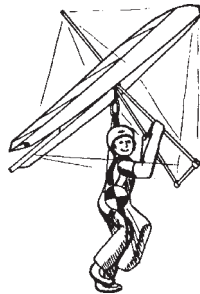

- b. Improper body position - pilot leaning back, (away from the anticipated hard landing), with feet extended in front. This moves the pilot's center of mass forward ahead of his shoulders, effectively shortening the pilot's arms and reducing flare authority. The proper position is with the pilot's body inclined forward, with the shoulders out ahead of the pilot's center of mass. Thinking about pushing “up” instead of “out” when flaring may help you to maintain the proper forward inclined body position.

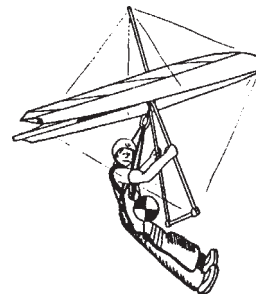
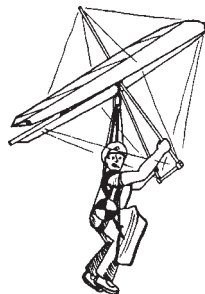

Falcon Breakdown

Breakdown of the glider is the reverse of assembly.

Note: Unlike gliders with tighter sails, the battens on the Falcon can be removed with the crossbar tensioned. Always remove the battens gently so as to avoid undue wear on the batten pockets or stress on the battens which may change their shape.

1. Set the glider at 90 degrees to the wind direction. Dismount the nose batten, and pull it out about 2" past the noseplate. Remove the #1 battens and 2 shortest cambered battens, roll the sail under at the tips, and install the tip cover bags.
2. Rotate the keyhole tang on the bottom of the noseplate to allow the keyhole tang to be disengaged. Disengage the tang by pulling down on the nose of the glider while pushing up with your thumbs on the plastic tang handle.

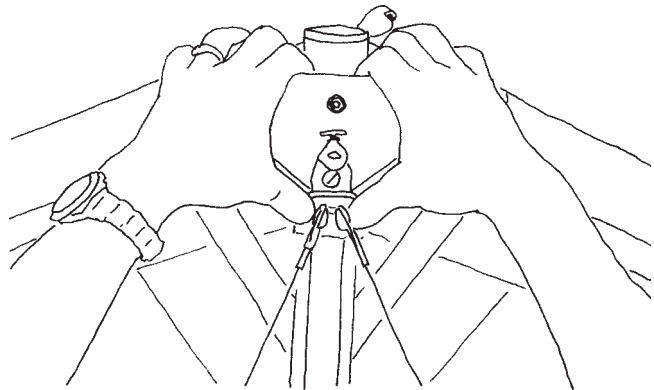
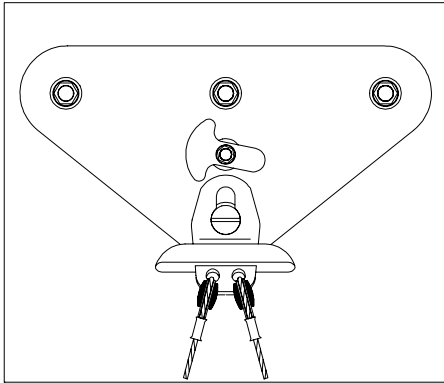

3. Pull back on the crossbar sweep wire and disengage the sweep wire, de-tensioning the crossbar.
4. Remove all the battens if you have not already done so, and remove the washout tips.
5. Fold the wings together, pulling the sail up over the top of the leading edges.
6. Lay the kingpost down forward against the keel.
7. If you elect to leave the bridles attached to the snap clip, grasp the sail at the inboard bridle location and fold it in and forward so that the sail lies clean and flat.

8. Roll the sail on each side around the number 1 batten and the washout tube.

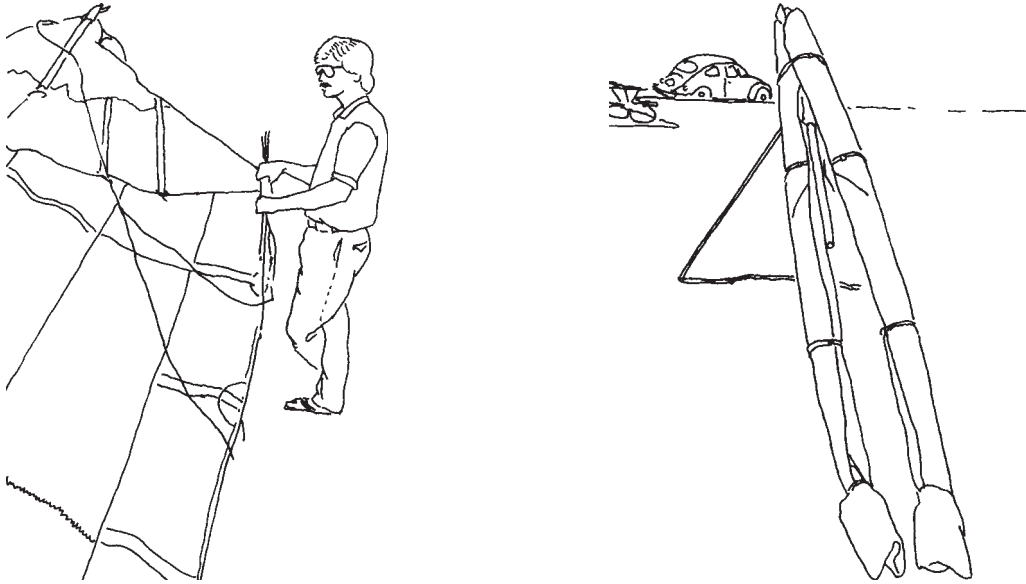

9. Secure the sail with the Velcro sail ties provided.

The wide, long Velcro strap is installed by passing it OVER THE TOP of the keel tube just forward of the control bar top, and then installing it around the glider leading edges. This holds the leading edges up away from the control bar apex hardware.

10. Place the glider bag on the glider, and flip the glider over onto the ground.
11. Detach the basetube, fold the control bar, and install the control bar bag and keel protective covers.
12. Stow the battens in the rear of the glider between the rear leading edges, and zip up the bag.

Falcon Stability Systems

Stability in pitch is provided by reflex in the root section, which is determined by the lengths of the kingpost, control bar, and front to rear top and bottom wires, and by the shape of the root battens, and by reflex support bridles running from the kingpost to the trailing edge at the number four, five, and six battens, and by washout tips installed in the leading edge underneath the number two battens.

Correct attachment and proper adjustment of the bridles are critical to providing adequate stability at low angles of attack, particularly those below the normal operating range.

Reflex bridle adjustment

On the Falcon 2 and Falcon Tandem models, the bridles are checked by measuring the supported height of the sail above the keel. The glider must be fully assembled as if it were to be flown in order to measure the bridles. String a light-weight piece of thread from the rear tip of each bridle batten, across the the corresponding batten on the other wing. The height in inches of this thread above the keel should be as follows:

<u>Model</u>	<u>Btn #7</u>	<u>Btn #6</u>	<u>Btn #5</u>	<u>Btn #4</u>
F2 140	na	5.5	11.5	16.5
F2 170	na	na	11.5	16.0
F2 195	na	8.5	12.5	15.25
F2 225	9.5	14.0	17.0	20.5
Tandem	9.5	13.5	16.5	19.5

On the Falcon 1 models, bridle adjustment is checked by a combination of measurement and flight testing, as described below. Starting with the glider fully assembled and ready to fly, hook a tape measure over the top front wire where it exits the kingpost cap, and measure to the sail trailing edge where seam line for the batten pocket for the bridle batten intersects the trailing edge. The measurements should be as follows:

<u>Model</u>	<u>Btn #7</u>	<u>Btn #6</u>	<u>Btn #5</u>	<u>Btn #4</u>
F1 140	na	57.875	77.75	106.5
F1 170	na	na	84.625	116.625
F1 195	na	71.5	99.375	134.0
F1 225	67.75	86.125	115.375	148.625

Final proper adjustment of the bridles is determined by sighting the shadow of the bridles on the sail in flight. With the glider in a 30 degree banked turn, at minimum sink speed, observe the shadow of the bridles on the sail, and then shake the control bar sharply and observe the movement of the shadow of each bridle line. Each bridle line should be between "just slack" and "slack" in adjustment, which means that there will be some slack evident in the bridle line as seen by a slight bow in the shadow of the cable, and the center of the bow in the line will move from one to four inches when you shake the bar.

Adjustment of the bridles requires replacing the bridle pigtail with one of a shorter (to tighten) or longer (to loosen) length, or placing tubular shims under the sail to shorten individual bridle lines.

Improper adjustment of the bridles will affect the glider's pitch stability and flight characteristics in the following ways:

Bridles too loose

If the bridles are adjusted too loose, it will not affect the glider in normal flight as the bridles are always slack in this range anyway. At angles of attack below normal flight, there will be a reduction in pitch stability proportional to the amount by which the bridles are looser than they are supposed to be. This stability reduction could increase the probability of a turbulence induced tumble or other in-flight stability related loss of control.

Bridles too tight

If the bridles are adjusted too tight, it will compromise the flight characteristics of the glider. The effects of too tight bridles are to increase roll control pressures and reduce roll rate in circumstances where maximum control input is applied.

Other factors of glider geometry which affect bridle adjustment and effectiveness

The effective adjustment of the bridles is also affected by other aspects of the glider geometry. For example, if the bottom side wires are too long, it will allow the wings to rise and slacken the bridles in normal flight. If they are too short, it will pull the wings down, and tighten the bridles in normal flight.

If the top side wires are too short, it will reduce the amount the wings can "fold" downwards as the glider unloads at low angles of attack, thereby reducing the effectiveness of the bridles.

Changes from proper length to the top or bottom side wires will also change the relative adjustment of the inner, middle, and outer bridles to each other, and change the way they operate.

Finally, normal shrinkage of the sail over time, by reducing the spanwise distance to the bridle attachment station, will loosen the bridle adjustment, and this should be corrected. Please see the Technical Bulletin on Reflex Bridle Adjustment And Maintenance (available in the Support section of the Wills Wing web site at www.willswing.com) for more information on maintaining and adjusting bridles.

Maintenance Schedule

You should continually maintain your glider in a proper state of tune and repair to insure optimum airworthiness, performance and flight characteristics. Failure to properly maintain your glider may lead to a dangerous loss of strength, stability or control responsiveness of the glider. Following any mishap that results in damage to the glider immediately have any damaged component repaired or replaced. We recommend that you have all such maintenance work done by your Wills Wing dealer. In addition, please follow the following maintenance schedule. Maintenance intervals are expressed in terms of calendar months and number of flights. You should perform the indicated maintenance at whichever comes first::

Every month or Every 30 flights.

1. Check your battens on a flat level surface following the instructions on the batten diagram provided, and correct any that deviate from the pattern in accordance with the instructions.

Every six months or Every 150 flights

1. Have a complete inspection performed on the glider and replace any component that shows any wear, and any cable that shows any kinks, wear, damage, corrosion, etc.
2. Inspect all bolts for tightness, all safeties for proper installation and possible damage. Inspect plates and fittings for damage, holes in tubes for elongation.
3. Inspect the sail for wear, tears, UV damage, loose stitching, etc.
4. Disassemble the control bar corner assemblies. Inspect the hardware fittings and the ball cable terminations to the front and rear flying wires. Replace any component with indications of permanent deformation or other damage.

Every twelve months or Every 300 flights

1. Have the sail completely removed from the frame, and disassemble all frame components. Inspect every part of the glider for any damage or wear. Inspect the tubes for straightness and for signs of corrosion. Anytime you have the sail off the frame inspect all of the batten pockets and batten pocket terminations.
2. Replace bottom side wires and hang loops.

Special circumstances

1. Any time you suffer a crash or extremely hard landing you should have an “annual” inspection done on your glider to insure that you find all damaged parts. If you bend a downtube, carefully inspect the companion control bar leg base plug and basetube bracket for damage.
2. If your glider is ever exposed to salt water you will need to have the glider completely disassembled in accordance with the recommended annual inspection procedure. All frame parts will need to be disassembled, including the removal of all sleeves, flushed liberally with fresh water, dried completely, and treated for corrosion inhibition with LPS-3 or other suitable agent.

3. **Cleaning Your Sail** - Keeping your sail clean will extend the life of the cloth. When cleaning the entire sail you should generally use only water and a soft brush. You may clean small spots or stains with any commercial spot remover that is labeled for use on polyester. Such cleaning agents are available at the supermarket or drug store, or you may order a cleaning solution from Wills Wing through your dealer.

A note about cables and cable maintenance:

The cables which support the glider's airframe are critical components of the glider's structure, and must be maintained in an air worthy condition. It is a general practice in the design of aircraft structures to design to an ultimate strength of 1.5 times the highest expected load in normal service. Hang glider cables, like other structural components on the glider, are typically designed with a structural safety factor of only about 50% above the expected maximum load. No significant loss in cable strength can be tolerated.

A cable with even a single broken strand must be replaced before the glider is flown again. A cable which has been bent sharply enough to have taken a permanent set (will not lie flat in a straight line when all tension is removed) must also be replaced immediately. If it is not, subsequent tensioning and de-tensioning of the cable will induce fatigue, and the cable will fail. In tests we have conducted, a cable bent one time to 90 degrees, and then loaded to the equivalent of a normal flight load 100 times (corresponding to 100 or fewer flights), failed at only 56% of its original strength.

Some degree of fatigue due to repeated bending of cables is almost unavoidable in an aircraft that is assembled and disassembled with every flight. Bottom side wires are subject to the highest loads in flight, and are therefore the most critical. This is why we recommend that these wires be replaced annually, even if there is no known damage. The requirement for immediate replacement of a cable known to have been bent or otherwise damaged supercedes this annual replacement requirement.

Replacement cables should always be obtained from the factory, or, if not from the factory, from a reliable source known to use proper fabrication procedures. An improperly made cable may appear perfectly OK on visual inspection, but could fail in flight at a load much below the intended design strength of the cable.

Removing The Sail From The Airframe And Reinstalling

Many maintenance and repair procedures will require the removal of the sail from the frame. Please follow these instructions when removing and reinstalling the sail. Please read all the instructions for each operation before beginning.

Sail removal

You will need an unobstructed area six feet by thirty feet. Make sure the surface is clean. If it is abrasive, like rough concrete, you should either put down a protective tarp or be extremely careful not to scrape your sail.

1. Lay the glider on its back, unzip and remove the glider bag and put the battens aside. Remove the control bar bag.
2. Remove the screws that secure the sail at the nose. Spread the wings slightly, undo the Velcro tabs inside the rear ends of the leading edges and then dismount the sail from the rear leading edges. Tape the sail plugs in position on the leading edges so that they do not become switched side to side inadvertently.
3. Unbolt the bottom side wires from the control bar. Remove the clevis pin which secures the control top elbows to the apex bracket. Unbolt the bottom rear flying wires from the rear keel. Reassemble the hardware removed onto the bolts in the original order so that it doesn't get lost. All disassembled assemblies on the glider must be reassembled in the proper order and orientation. Use the exploded parts diagrams in this manual to help you. On the bottom rear wire, the relative position of the washers, saddles and tangs affects the front to rear wire tension.
4. Set the control bar aside.
5. Turn the glider over. Unroll the sail until you can reach the bridle attachments at the trailing edge. Remove the plastic bridle retainer balls and disconnect the bridles from the sail.
6. Remove the screw that holds the kingpost top cap in place and carefully remove the cap. Remove the top front and top side wires from the kingpost top. Reinstall the cap. Unbolt the kingpost from the keel. Set the kingpost aside.
7. Feed the top and bottom side wires into the sail through the holes in the sail. Turn the glider over onto its back again. Disassemble the crossbar center section, and fold the crossbar halves to the rear to align with the leading edges. Slide the frame out through the nose of the glider. If you encounter resistance, stop and find out what is hanging up.
9. If you need to send the sail into the factory for repair, fold and package the sail carefully. Be sure to include written instructions of what you want done, your name and a phone number where you can be reached during the day.

Reinstalling the sail on the frame

1. Position the sail on the floor with the keel pocket up and the wings folded over so that the leading edges lie along the length of the root line, with the top of the leading edge lying on top.
2. Prepare the frame, making sure that the side wires are pulled forward from the crossbar leading edge junction and are not wrapped around the frame. The crossbar halves should be separate, and swung aft to be aligned with the leading edges.
3. Position the frame with the bottom of the noseplate facing up and with the rear end of the leading edges at the nose of the sail. Slide the frame into the nose of the sail, making sure that the leading edges of the frame and the crossbar halves pass properly into the leading edge pockets of the sail and don't get caught at the rear of the bottom surface near the root. As you feed the frame slowly into the sail, check periodically to see that none of the hardware is snagging on the sail. As the crossbar ends reach the leading edge junction cut outs in the sail, bring them out through these holes.
4. After the frame is fully installed, mount the webbing anchor loops over the rear leading edge endcaps. Make sure you mount the inner webbing loops in the endcap slots, not the outer "handle" loops! Make sure that the webbing lies flat and smooth in the slot, and that the sail is properly aligned when mounted. Secure the Velcro retainer tabs.
5. Working through the crossbar cut out hole, insert the top wires through the holes in the sail, making sure that no cable is wrapped around a leading edge or crossbar, and that no thimbles are cocked or twisted. Pull the bottom side wires out through the crossbar cut out hole.
6. Bolt the bottom rear wires to the rear of the keel attaching the rear sail mount at the same time. Install the control bar onto the apex bracket, and attach the bottom side wires to the control bar corners.
7. Flip the glider up onto the control bar. Working through the nose, insert the top front wire up through the hole in the sail.
8. Reinstall all the top wires onto the kingpost.
9. Spread the wings slowly and carefully, making sure that the sail rides forward as necessary at the nose without catching. Be careful: you can easily tear the sail open at the nose at this point. Reinstall the nose screws after the sail is fully spread.
10. Bolt the kingpost bracket to the keel. Connect the top rear wire, and the bottom front wires. Connect the bridles to the sail.
11. Finish the assembly of the glider completely according to normal assembly procedures.
12. Do a very careful and complete preflight of the glider according to the normal preflight procedure as explained earlier in this manual.

Tuning

Dismounting and remounting the sail at the tip

A number of tuning procedures require you to dismount the sail at the rear leading edge. This can be most easily accomplished by using a large, flat bladed screw driver to pry the sail mount webbing off of the end of the leading edge. The same technique can be used to reinstall the sail. Take care not to damage the sail mount webbing, and when remounting the sail, be sure to mount the inner webbing in the slot, not the outer handle webbing, and be sure that the webbing seats squarely in the slot.

CG adjustment

has already been covered in the section of this manual on using your wing tufts. Wills Wing recommends that tuning other than CG adjustment be performed by your Wills Wing dealer.

Turn trim

Turns are caused by an asymmetry in the glider. If you have a turn, first try to make the glider symmetrical in every way.

Airframe

Check the leading edges for possible bent tubes. Check that the keel is not bent to one side.

Check for symmetrical twist in the leading edges by checking for symmetry in the alignment of the sail mount plugs.

Battens

Check the battens for symmetrical shape and batten string tension.

Sail mount plugs - adjusting sail tension and rotational alignment

There are two types of sail mount plugs used on the Falcon - the original rivet type plug, and the newer allen screw type.

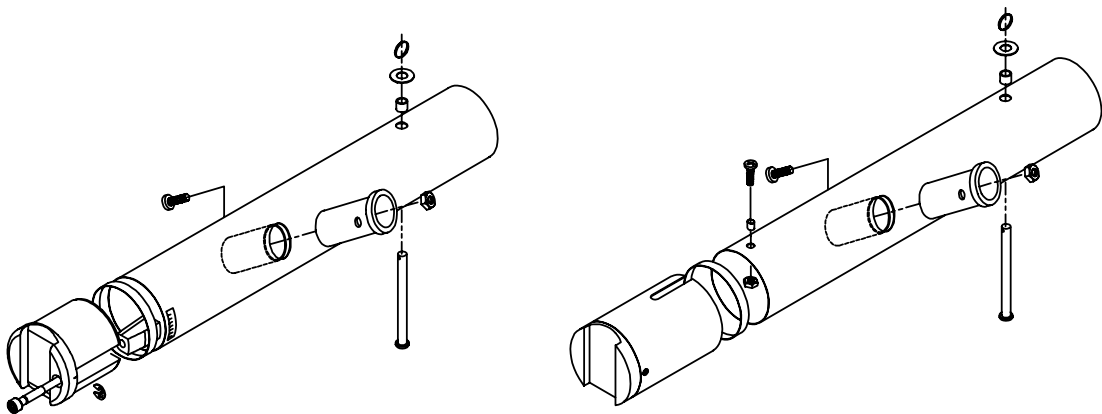

In the rivet type plug, the plastic sail mount endcap is secured to a short 52mm oversleeve with an 1/8" pop rivet. The oversleeve slides over the rear leading edge, and is secured against rotation by a notch on the oversleeve which engages a small screw on the rear leading edge. Shims are located inside the

oversleeve which determine the sail mount tension.

Rotating the plastic sail mount endcap requires drilling out the pop rivet, rotating the endcap, and drilling a new hole for a new pop rivet.

Adding or removing shims requires dismounting the sail mount strap, and then sliding the oversleeve plug off the end of the leading edge. Shims are added to or removed from inside the oversleeve plug.

In the allen screw type plug, the molded plastic plug fits directly into the rear leading edge. It is secured against rotation by a sliding wedge which is forced out against the inside of the tube as the allen screw is tightened. The proper installation procedure for this plug is to engage the allen screw three turns into the sliding wedge, install the plug into the rear leading edge, set the desired alignment, and then tighten the allen screw 15 additional turns.

Shims are added to the allen screw type plug by sliding them over the end of the plug before the plug is inserted into the leading edge. The shims are thus visible with the plug installed.

Once the allen screw type plug is installed, the rotational alignment can be changed by loosening the allen screw to relieve the pressure of the wedge against the inside of the leading edge tube until the sail mount plug is free enough that it can be rotated.

If you loosen the screw too much, the wedge will fall off inside the leading edge tube, and you will have to dismount the sail to retrieve it.

Sail tension

Check for symmetrical sail tension on the leading edges. In order to check this, remove the sail mount screws at the nose, detension and re-tension the xbar and sight the hem of the sail at the bottom of the leading edge tube relative to the noseplate on each side. Sail tension is adjusted by adding or removing shims in 1/8" or 1/4" increments to or from the sail mount plugs on the rear ends of the leading edges. See the discussion above about the different types of sail mount plugs and how shims are added or removed.

To remove or add shims from either plug, first dismount the sail mount webbing by pulling it free and then to the outside of the leading edge. You can use a flat bladed screwdriver to pry the webbing off, but take care not to damage the webbing. After dismounting the sail, the oversleeve type plug will simply slide off the leading edge. To remove the other type of plug, first check and record the rotational alignment by noting the position of the scribe mark on the plug relative to the scale on the leading edge tube. Use the allen wrench provided in your spare parts kit to loosen the allen screw until you can remove the plug. Add or remove shims as necessary, and then reinstall the plug, making sure the alignment is correct. On the allen screw type sail plug, fifteen turns of the allen screw after installation of the plug will secure the plug in place.

Make sure to replace the sail mount screws at the nose.

Twisting a tip

After you have made everything symmetrical, if you still have a turn, you will correct it by rotating one or both sail mount plugs. A left turn is corrected by twisting the left sail plug clockwise (twisting the sail down at the trailing edge) or twisting the right sail plug clockwise (twisting the sail up at the trailing edge) or both. Twist counter clockwise on either or both plugs to correct a right turn. In the rivet type

plug, the sail mount plug is secured by a 1/8" diameter pop rivet. To rotate the plug, drill out this rivet, rotate the plug within the sleeve, and re-drill the plug and install a new rivet. The recommended adjustment amount is one rivet hole diameter per adjustment and test flight.

To rotate the allen screw type sail plug, use the allen wrench provided in your spare parts kit to loosen the allen screw thus pushing the wedge forward and releasing the plug.

If you loosen the screw too much, the wedge will fall off the end of the screw inside the leading edge, and you will have to dismount the sail to retrieve it. Start by loosening the screw ten turns, and then check to see if you can rotate it. If not, loosen it one turn at a time until it can be rotated.

After rotating the plug in the desired amount in the desired direction, (see above) tighten the screw to secure the plug against rotation. When the screw is properly tightened, there will be a slight bulge (less than or equal to the wall thickness of the tube) in the rear leading edge tube adjacent to the screw.

Adjusting batten tension

All battens on the Falcon 1 models, and the tip battens on the Falcon 2 and Falcon Tandem models, are tensioned by looping the batten string over the notched end of the batten twice. The inboard batten strings should be slightly on the loose side, and the outboard batten strings should be progressively more firm. The number one batten strings should be fairly snug, but not so tight as to buckle the #1 batten or slacken the sail mount webbing which mounts the sail at the tip. Note: We have found that if the plug on #1 battens are adjusted too tight on the Falcon 2 195 and 225, it can cause the glider to enter a spin when stalled in a turn. If you experience this tendency, try loosening the number one battens, and rotating the sail mount plugs by one to two marks on the index in the direction so as to raise the trailing edge at the tip (increase wing twist).

With regard to the spring tip battens on the Falcon 2's, the springs will automatically provide the proper tension. However, if the battens are too long, you will find that they are difficult to install. This is not an issue of the tension in the spring, it happens because at the point at which the shoulder of the batten tip bottoms out against the rear end of the batten tubing, the batten is still too long to be able to pull the trailing edge hem over the end of the batten tip. It is easy to check the batten lengths to see if they are correct. With the glider fully set up, and the battens all installed, measure the gap between the cut rear end of the batten tube and the shoulder of the rear batten tip (the part of the batten tip which will bottom out against the tube when the tip is fully compressed into the batten as far as it will go). This gap should be at least 11 mm (7/16"). If it is less than that, the battens will be difficult to install.

If the gap is within 3mm (1/8") of being correct, you can fix the problem by cutting 1/8" off of the rear end of the rear plastic tip. (You can't cut more than that off, because then the length of the part of the tip that fits into the hem of the sail will be shorter than the width of the hem.) If you need to shorten the batten more than that, you will need to remove the rear plastic tip, cut the batten tube down, and re-install the tip. If you need to shorten the batten tube by more than 1/4", you will also need to shorten the spring, otherwise the spring tension will be too high, and the spring will be deformed by being over-compressed. For more information on spring batten adjustments and batten tip removal and replacement, see the appropriate Technical Bulletins in the Support section of the Wills Wing web site at www.willswing.com.

Leading edge sail tension

The tension in the leading edge of the sail, adjustable by shimming as described above, will influence the performance and handling of the glider. If the sail is mounted too loose, the performance will deteriorate noticeably. If the sail is mounted too tight, the glider will handle poorly; it will be stiff and slow in roll response with excessive adverse yaw and an increased tendency to spin in a stalled turn. As the glider gets older and the sail stretches, you will need to add shims to maintain the proper tension.

Car Top Mounting And Transport

Improper or careless transport of your glider can cause significant damage. You should transport your glider on a rack which has at least three support points which span at least 13' of the length of the glider. These should be well padded and at least four inches wide to distribute the load. Your glider should be mounted on your rack with the control bar facing up. It should be securely tied down with webbing straps which are at least 1/2" wide. If you drive on rough roads where the glider receives impact loads, you should take extra care to pad your glider internally when you pack it up. One special area to pay attention to is the forward area of the glider where the crossbar center section bears against the top of the leading edge tubes, and the kingpost sits on top of the keel. Some extra padding inserted in this area will save wear on your airframe and sail.

In Closing

With proper care and maintenance, your glider will retain a high level of airworthiness for some years. Because of the relatively short history of hang gliding, and the rapid advances in new designs, we do not have a lot of information about the ultimate service life of a hang glider. We do know that ultraviolet (UV) damage to the sail from sunlight is probably the limiting factor in the life of your sail. Try to avoid exposing your sail to sunlight any time you are not actually flying it.

We also know that there are forces in nature which can be so violent that they can result in fatal accidents regardless of the airworthiness of your aircraft. Ultimately your safety is your responsibility. Know the limitations of your knowledge, skill and experience, and know the limitations of your aircraft. Fly within those limitations.

Have fun.

See you in the sky!

Wills Wing, Inc.

HGMA COMPLIANCE VERIFICATION SPECIFICATION SHEET

GLIDER MODEL Falcon 140
MANUFACTURED BY Wills Wing Inc.

All dimensions in inches; weights in pounds.

NOTE: These specifications are intended only as a guideline for determining whether a given glider is a certified model and whether it is in the certified configuration.

Be aware, however, that no set of specifications, however detailed, can guarantee the ability to determine whether a glider is the same model, or is in the same configuration as was certified, or has those performance, stability, and structural characteristics required by the certification standards. An owner's manual is required to be delivered with each HGMA certified glider, and it is required that it contain additional airworthiness information.

1. Weight of glider with all essential parts and without coverbags and nonessential parts: 42 lbs
2. Leading Edge Dimensions
 - a. Nose plate anchor hole to:
 1. Crossbar attachment hole 107
 2. Rear sail attachment point 189.75 - 191.0
 - b. Outside diameter at:
 1. Nose 2.05
 2. Crossbar 2.05
3. Rear sail attachment point 2.05
3. Crossbar Dimensions
 - a. Overall pin to pin length from leading edge attachment point to hinge bolt at glider centerline 93.46
 - b. Largest outside diameter 1.97
4. Keel dimensions; least and greatest allowable distances, whether variable through tuning or through in-flight variable geometry, from the line joining the leading edge nose bolts to:
 - a. The xbar center load bearing pin 44.125 +/- .75
 - b. The pilot hang loop 56 +/- 2.0
5. Sail Dimensions
 - a. Chord lengths at:
 1. 3 ft outboard of centerline 76.4
 2. 3 ft inboard of tip 46
 - b. Span (extreme tip to tip) 334.2
6. Location of Information Placard Keel
Location of Test Fly Sticker Keel
7. Recommended Pilot Weight Range 120 - 210
8. Recommended Pilot Proficiency USHGA Novice

HGMA COMPLIANCE VERIFICATION SPECIFICATION SHEET

GLIDER MODEL Falcon 170
MANUFACTURED BY Wills Wing Inc.

All dimensions in inches; weights in pounds.

NOTE: These specifications are intended only as a guideline for determining whether a given glider is a certified model and whether it is in the certified configuration.

Be aware, however, that no set of specifications, however detailed, can guarantee the ability to determine whether a glider is the same model, or is in the same configuration as was certified, or has those performance, stability, and structural characteristics required by the certification standards. An owner's manual is required to be delivered with each HGMA certified glider, and it is required that it contain additional airworthiness information.

1. Weight of glider with all essential parts and without coverbags and nonessential parts: 46 lbs
2. Leading Edge Dimensions
 - a. Nose plate anchor hole to:
 1. Crossbar attachment hole 119.5
 2. Rear sail attachment point 209.25 - 210.5
 - b. Outside diameter at:
 1. Nose 2.05
 2. Crossbar 2.05
 3. Rear sail attachment point 2.05
3. Crossbar Dimensions
 - a. Overall pin to pin length from leading edge attachment point to hinge bolt at glider centerline 104.7
 - b. Largest outside diameter 2.00
4. Keel dimensions; least and greatest allowable distances, whether variable through tuning or through in-flight variable geometry, from the line joining the leading edge nose bolts to:
 - a. The xbar center load bearing pin 50 +/- .75
 - b. The pilot hang loop 61.5 +/- 2.0
5. Sail Dimensions
 - a. Chord lengths at:
 1. 3 ft outboard of centerline 85.8
 2. 3 ft inboard of tip 49.6
 - b. Span (extreme tip to tip) 367.2
6. Location of Information Placard Keel
Location of Test Fly Sticker Keel
7. Recommended Pilot Weight Range 140 - 230
8. Recommended Pilot Proficiency USHGA Novice

HGMA COMPLIANCE VERIFICATION SPECIFICATION SHEET

GLIDER MODEL Falcon 195
MANUFACTURED BY Wills Wing Inc.

All dimensions in inches; weights in pounds.

NOTE: These specifications are intended only as a guideline for determining whether a given glider is a certified model and whether it is in the certified configuration.

Be aware, however, that no set of specifications, however detailed, can guarantee the ability to determine whether a glider is the same model, or is in the same configuration as was certified, or has those performance, stability, and structural characteristics required by the certification standards. An owner's manual is required to be delivered with each HGMA certified glider, and it is required that it contain additional airworthiness information.

1. Weight of glider with all essential parts and without coverbags and nonessential parts: 49 lbs
2. Leading Edge Dimensions
 - a. Nose plate anchor hole to:
 1. Crossbar attachment hole 139
 2. Rear sail attachment point 229.25 - 230.5
 - b. Outside diameter at:
 1. Nose 2.05
 2. Crossbar 2.05
 3. Rear sail attachment point 2.05
3. Crossbar Dimensions
 - a. Overall pin to pin length from leading edge attachment point to hinge bolt at glider centerline 122.21
 - b. Largest outside diameter 2.44
4. Keel dimensions; least and greatest allowable distances, whether variable through tuning or through in-flight variable geometry, from the line joining the leading edge nose bolts to:
 - a. The xbar center load bearing pin 56 +/- .75
 - b. The pilot hang loop 64.75 +/- 1.5
5. Sail Dimensions
 - a. Chord lengths at:
 1. 3 ft outboard of centerline 91
 2. 3 ft inboard of tip 48
 - b. Span (extreme tip to tip) 395.5
6. Location of Information Placard Keel
Location of Test Fly Sticker Keel
7. Recommended Pilot Weight Range 150 - 275
8. Recommended Pilot Proficiency USHGA Novice

HGMA COMPLIANCE VERIFICATION SPECIFICATION SHEET

GLIDER MODEL Falcon 225
MANUFACTURED BY Wills Wing Inc.

All dimensions in inches; weights in pounds.

NOTE: These specifications are intended only as a guideline for determining whether a given glider is a certified model and whether it is in the certified configuration.

Be aware, however, that no set of specifications, however detailed, can guarantee the ability to determine whether a glider is the same model, or is in the same configuration as was certified, or has those performance, stability, and structural characteristics required by the certification standards. An owner's manual is required to be delivered with each HGMA certified glider, and it is required that it contain additional airworthiness information.

1. Weight of glider with all essential parts and without coverbags and nonessential parts: 59 lbs
2. Leading Edge Dimensions
 - a. Nose plate anchor hole to:
 1. Crossbar attachment hole 147
 2. Rear sail attachment point 244.5 - 245.25
 - b. Outside diameter at:
 1. Nose 2.05
 2. Crossbar 2.05
 3. Rear sail attachment point 2.05
3. Crossbar Dimensions
 - a. Overall pin to pin length from leading edge attachment point to hinge bolt at glider centerline 129.21
 - b. Largest outside diameter 2.44
4. Keel dimensions; least and greatest allowable distances, whether variable through tuning or through in-flight variable geometry, from the line joining the leading edge nose bolts to:
 - a. The xbar center load bearing pin 57.7 +/- .75
 - b. The pilot hang loop 70.5 +/- 2.0
5. Sail Dimensions
 - a. Chord lengths at:
 1. 3 ft outboard of centerline 97.6
 2. 3 ft inboard of tip 48
 - b. Span (extreme tip to tip) 428.8
6. Location of Information Placard Keel
Location of Test Fly Sticker Keel
7. Recommended Pilot Weight Range 185 - 440
8. Recommended Pilot Proficiency USHGA Novice

HGMA COMPLIANCE VERIFICATION SPECIFICATION SHEET

GLIDER MODEL Falcon 2 140
MANUFACTURED BY Wills Wing Inc.

All dimensions in inches; weights in pounds.

NOTE: These specifications are intended only as a guideline for determining whether a given glider is a certified model and whether it is in the certified configuration.

Be aware, however, that no set of specifications, however detailed, can guarantee the ability to determine whether a glider is the same model, or is in the same configuration as was certified, or has those performance, stability, and structural characteristics required by the certification standards. An owner's manual is required to be delivered with each HGMA certified glider, and it is required that it contain additional airworthiness information.

1. Weight of glider with all essential parts and without coverbags and nonessential parts: 43 lbs
2. Leading Edge Dimensions
 - a. Nose plate anchor hole to:
 1. Crossbar attachment hole 107
 2. Rear sail attachment point 189.75 - 190.5
 - b. Outside diameter at:
 1. Nose 2.05
 2. Crossbar 2.05
3. Rear sail attachment point 1.97
3. Crossbar Dimensions
 - a. Overall pin to pin length from leading edge attachment point to hinge bolt at glider centerline 93.46
 - b. Largest outside diameter 1.97
4. Keel dimensions; least and greatest allowable distances, whether variable through tuning or through in-flight variable geometry, from the line joining the leading edge nose bolts to:
 - a. The xbar center load bearing pin 44.125 +/- .75
 - b. The pilot hang loop 57.75 +/- 1.5
5. Sail Dimensions
 - a. Chord lengths at:
 1. 3 ft outboard of centerline 77.6
 2. 3 ft inboard of tip 46.0
 - b. Span (extreme tip to tip) 334.2
6. Location of Information Placard Keel
Location of Test Fly Sticker Keel
7. Recommended Pilot Weight Range 120 - 190
8. Recommended Pilot Proficiency USHGA Novice

HGMA COMPLIANCE VERIFICATION SPECIFICATION SHEET

GLIDER MODEL Falcon 2 170
MANUFACTURED BY Wills Wing Inc.

All dimensions in inches; weights in pounds.

NOTE: These specifications are intended only as a guideline for determining whether a given glider is a certified model and whether it is in the certified configuration.

Be aware, however, that no set of specifications, however detailed, can guarantee the ability to determine whether a glider is the same model, or is in the same configuration as was certified, or has those performance, stability, and structural characteristics required by the certification standards. An owner's manual is required to be delivered with each HGMA certified glider, and it is required that it contain additional airworthiness information.

1. Weight of glider with all essential parts and without coverbags and nonessential parts: 48 lbs
2. Leading Edge Dimensions
 - a. Nose plate anchor hole to:
 1. Crossbar attachment hole 119.5
 2. Rear sail attachment point 209.25 - 210
 - b. Outside diameter at:
 1. Nose 2.05
 2. Crossbar 2.05
 3. Rear sail attachment point 1.97
3. Crossbar Dimensions
 - a. Overall pin to pin length from leading edge attachment point to hinge bolt at glider centerline 104.7
 - b. Largest outside diameter 2.00
4. Keel dimensions; least and greatest allowable distances, whether variable through tuning or through in-flight variable geometry, from the line joining the leading edge nose bolts to:
 - a. The xbar center load bearing pin 50 +/- .75
 - b. The pilot hang loop 62.25 +/- 1.5
5. Sail Dimensions
 - a. Chord lengths at:
 1. 3 ft outboard of centerline 86.2
 2. 3 ft inboard of tip 48
 - b. Span (extreme tip to tip) 367.2
6. Location of Information Placard Keel
Location of Test Fly Sticker Keel
7. Recommended Pilot Weight Range 140 - 220
8. Recommended Pilot Proficiency USHGA Novice

HGMA COMPLIANCE VERIFICATION SPECIFICATION SHEET

GLIDER MODEL Falcon 2 195
MANUFACTURED BY Wills Wing Inc.

All dimensions in inches; weights in pounds.

NOTE: These specifications are intended only as a guideline for determining whether a given glider is a certified model and whether it is in the certified configuration.

Be aware, however, that no set of specifications, however detailed, can guarantee the ability to determine whether a glider is the same model, or is in the same configuration as was certified, or has those performance, stability, and structural characteristics required by the certification standards. An owner's manual is required to be delivered with each HGMA certified glider, and it is required that it contain additional airworthiness information.

1. Weight of glider with all essential parts and without coverbags and nonessential parts: 53 lbs
2. Leading Edge Dimensions
 - a. Nose plate anchor hole to:
 1. Crossbar attachment hole 133
 2. Rear sail attachment point 229.25 - 230.0
 - b. Outside diameter at:
 1. Nose 2.05
 2. Crossbar 2.05
 3. Rear sail attachment point 1.97
3. Crossbar Dimensions
 - a. Overall pin to pin length from leading edge attachment point to hinge bolt at glider centerline 116.84
 - b. Largest outside diameter 2.25 or 2.44
4. Keel dimensions; least and greatest allowable distances, whether variable through tuning or through in-flight variable geometry, from the line joining the leading edge nose bolts to:
 - a. The xbar center load bearing pin 5.0 +/- .25
 - b. The pilot hang loop 67.25 +/- 1.5
5. Sail Dimensions
 - a. Chord lengths at:
 1. 3 ft outboard of centerline 91.7
 2. 3 ft inboard of tip 48
 - b. Span (extreme tip to tip) 395.5
6. Location of Information Placard Keel
Location of Test Fly Sticker Keel
7. Recommended Pilot Weight Range 150 - 250
8. Recommended Pilot Proficiency USHGA Novice

HGMA COMPLIANCE VERIFICATION SPECIFICATION SHEET

GLIDER MODEL Falcon 2 225
MANUFACTURED BY Wills Wing Inc.

All dimensions in inches; weights in pounds.

NOTE: These specifications are intended only as a guideline for determining whether a given glider is a certified model and whether it is in the certified configuration.

Be aware, however, that no set of specifications, however detailed, can guarantee the ability to determine whether a glider is the same model, or is in the same configuration as was certified, or has those performance, stability, and structural characteristics required by the certification standards. An owner's manual is required to be delivered with each HGMA certified glider, and it is required that it contain additional airworthiness information.

1. Weight of glider with all essential parts and without coverbags and nonessential parts: 61 lbs
2. Leading Edge Dimensions
 - a. Nose plate anchor hole to:
 1. Crossbar attachment hole 147
 2. Rear sail attachment point 244.5 - 245.25
 - b. Outside diameter at:
 1. Nose 2.05
 2. Crossbar 2.05
 3. Rear sail attachment point 1.97
3. Crossbar Dimensions
 - a. Overall pin to pin length from leading edge attachment point to hinge bolt at glider centerline 129.21
 - b. Largest outside diameter 2.5 or 2.44
4. Keel dimensions; least and greatest allowable distances, whether variable through tuning or through in-flight variable geometry, from the line joining the leading edge nose bolts to:
 - a. The xbar center load bearing pin 57.7 +/- .25
 - b. The pilot hang loop 70.75 +/- 1.5
5. Sail Dimensions
 - a. Chord lengths at:
 1. 3 ft outboard of centerline 102.3
 2. 3 ft inboard of tip 48
 - b. Span (extreme tip to tip) 428.8
6. Location of Information Placard Keel
Location of Test Fly Sticker Keel
7. Recommended Pilot Weight Range 185 - 300
8. Recommended Pilot Proficiency USHGA Novice

HGMA COMPLIANCE VERIFICATION SPECIFICATION SHEET

GLIDER MODEL Falcon Tandem
MANUFACTURED BY Wills Wing Inc.

All dimensions in inches; weights in pounds.

NOTE: These specifications are intended only as a guideline for determining whether a given glider is a certified model and whether it is in the certified configuration.

Be aware, however, that no set of specifications, however detailed, can guarantee the ability to determine whether a glider is the same model, or is in the same configuration as was certified, or has those performance, stability, and structural characteristics required by the certification standards. An owner's manual is required to be delivered with each HGMA certified glider, and it is required that it contain additional airworthiness information.

1. Weight of glider with all essential parts and without coverbags and nonessential parts: 71 lbs
2. Leading Edge Dimensions
 - a. Nose plate anchor hole to:
 1. Crossbar attachment hole 147
 2. Rear sail attachment point 244.5 - 245.25
 - b. Outside diameter at:
 1. Nose 2.00
 2. Crossbar 2.00
 3. Rear sail attachment point 2.00
3. Crossbar Dimensions
 - a. Overall pin to pin length from leading edge attachment point to hinge bolt at glider centerline 129.21
 - b. Largest outside diameter 2.5 or 2.44
4. Keel dimensions; least and greatest allowable distances, whether variable through tuning or through in-flight variable geometry, from the line joining the leading edge nose bolts to:
 - a. The xbar center load bearing pin 57.7 +/- .25
 - b. The pilot hang loop 70.75 +/- 1.5
5. Sail Dimensions
 - a. Chord lengths at:
 1. 3 ft outboard of centerline 102.3
 2. 3 ft inboard of tip 48
 - b. Span (extreme tip to tip) 430
6. Location of Information Placard Keel
Location of Test Fly Sticker Keel
7. Recommended Pilot Weight Range 185 - 500
8. Recommended Pilot Proficiency USHGA Novice

ID	PART NO	DESCRIPTION	QNT
1A	20G-1613	BRACKET KEEL CNTR FALCON 52MM	1
1B	20G-1612	BRACKET KEEL CNTR FALCON 44MM	1
2	10G-3590	CLEVIS PIN MS20392-4C59	1
3	10T-5114	BUSH SPLIT HEADED AT CB LONG	2
4	20G-1412	CBAR PLUG AT LEG TOP ROUND	2
6	10G-1370	CLEVIS PIN MS20392-2C37	2
8	10C-5171	BOLT MAS 623-4-17	2
9	40P-3301	WIRE SET BOTTOM REAR BALL SWDG	1
10	20G-1402	CBAR PLUG AT LEG BOTM ROUND 95	2
11	40P-3201	WIRE SET BOTTM FRONT BALL SWDG	1
12	10N-1740	CLINCH NUT 1/4 MS21042-4	5
13A	40P-3104	WIRE BTM SIDE 1/8 AT (195,225)	2
13B	40P-3103	WIRE BTM SIDE 3/32 AT (140,170)	2
14A	20G-1801	CBAR BRACKET AT BASE/TUBE END	2
14B	20G-1804	CBAR BRACKET AT BASE/WHEELS	2
15	10C-5121	BOLT MAS 623-4-12	2
16	10C-5171	BOLT MAS 623-4-17	1
18	10N-1440	WINGNUT 1/4 AN350-4	1
19	10P-1200	SAFETY RING AN R2 LARGE	1
20	10C-5181	BOLT MAS 623-4-18	1
21	10P-1300	SAFETY RING MEDIUM THICK	1
22	20G-1701	CBAR ELBOW AT TOP ROUND	2
23	10U-5125	WASHER NYLON .75 * .316 * .020	2
24A	10C-2341	BOLT MAS 517-4-34 (195,225)	1
24B	10C-2291	BOLT MAS 517-4-29 (140,170)	1
25	10P-1100	SAFETY RING AN 9491 SMALL	1
CONTROL BAR BASE OPTIONS DEPENDING ON SIZE AND MODEL			
17	40F-1310	BASE TUBE AT 60 STRAIGHT	1
	40F-1311	BASE TUBE AT 60 SPEEDBAR	
	40F-1315	BASE CPLT ASSY AT60 FOLD NO BR	
	40F-1316	BASE TUBE AT 60 STRAIGHT .095	
	40F-1320	BASE TUBE AT 62 STRAIGHT	
	40F-1321	BASE TUBE AT 62 SPEEDBAR	
	40F-1325	BASE CPLT ASSY AT62 FOLD NO BR	
	40F-1326	BASE TUBE AT 62 STRAIGHT .095	
	40F-1330	BASE TUBE AT 65 STRAIGHT	
	40F-1331	BASE TUBE AT 65 SPEEDBAR	
	40F-1335	BASE CPLT ASSY AT65 FOLD NO BR	
	40F-1336	BASE TUBE AT 65 STRAIGHT .095	
	40F-1350	BASE TUBE AT 68+4 STRAIGHT	
	40F-1351	BASE TUBE AT 68+4 SPEEDBAR	
	40F-1355	BASE CPL ASSY AT68+4 FLD NO BR	
	40F-1356	BASE TUBE AT 68+4 STRAIGHT .095	
CONTROL BAR LEG OPTIONS DEPENDING ON SIZE			
7	40G-1210	LEG AT 60 .065 ROUND	2
	40G-1220	LEG AT 62 .065 ROUND	
	40G-1235	LEG AT 65 .065 ROUND W/ SLEEVE	

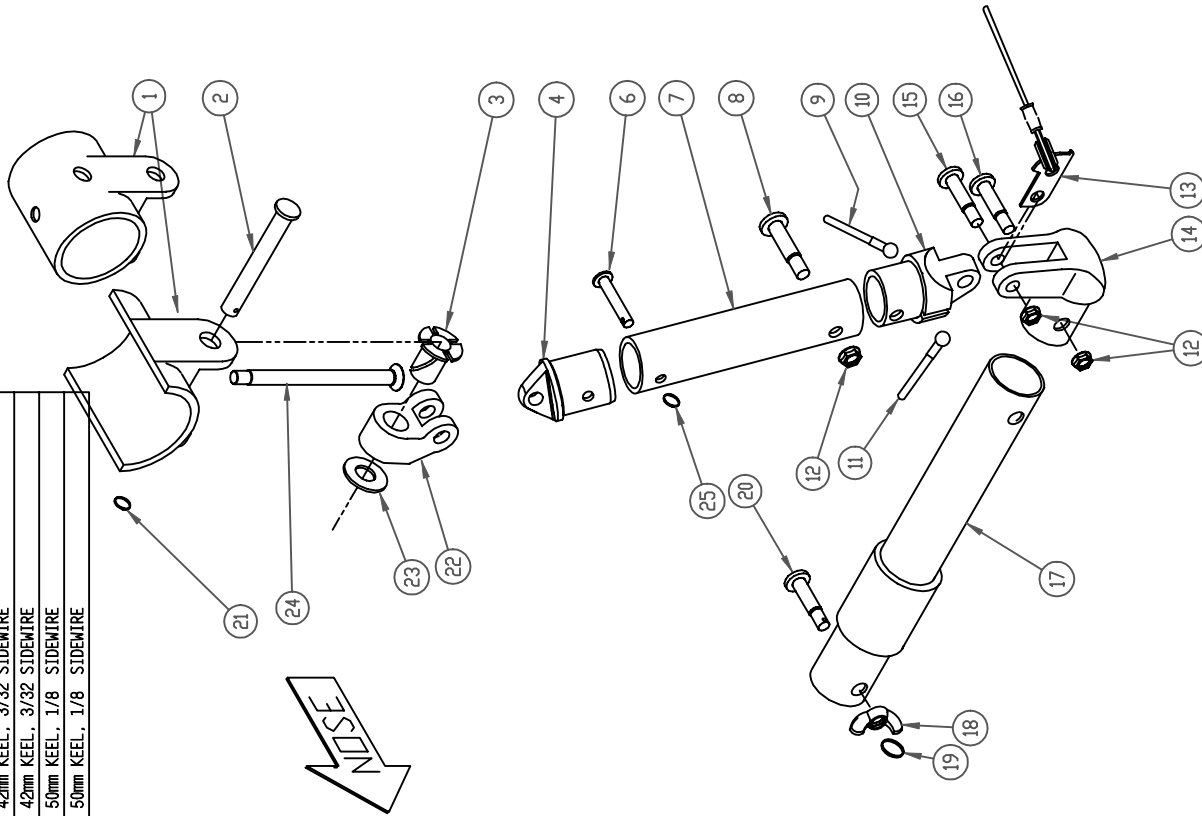

Falcon Round Control Bar

WALLS WING
 500 BLUERIDGE AVE. ORANGE • CA • 92665 • PH/FAX (714) 998-6359 / 998-0647
 DOCUMENT ID: 75E012
 DWG ID: ISO_FALC.DWG
 DRAWN: R 04-29-97 SP
 TITLE:

FALCON CONTROL BAR, KEEL AND SIDEWIRE	
FALCON 140	AT60, 42mm KEEL, 3/32 SIDEWIRE
FALCON 170	AT62, 42mm KEEL, 3/32 SIDEWIRE
FALCON 195	AT65, 50mm KEEL, 1/8 SIDEWIRE
FALCON 225	AT68, 50mm KEEL, 1/8 SIDEWIRE

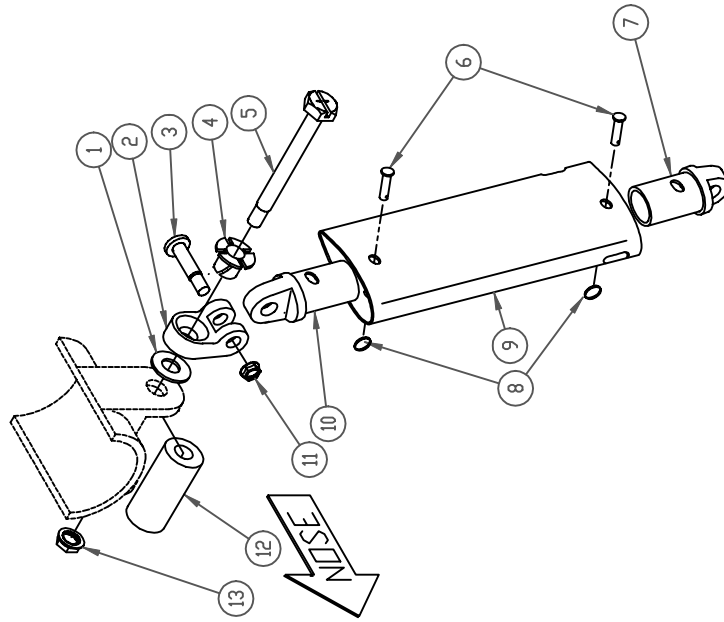

ID	PART NO	DESCRIPTION	QNT
1	10U-5125	WASHER NYLON .75 * .316 * .020	2
2	20G-1711	CBAR ELBOW AT TOP STREAM	2
3	10C-5111	BOLT MAS 623-4-11	2
4	10T-5113	BUSH SPLIT HEADED AT CB SHORT	2
5	10A-3272	BOLT AN5-27A GROUND & SLOTTED	1
6	10G-1330	CLEVIS PIN MS20392-2C33	4
7	20G-1424	CBAR PLUG AT LEG BOT STR TOE95	2
8	10P-1100	SAFETY RING AN 9491 SMALL	4
10	20G-1433	CBAR PLUG AT LEG TOP STR TOEIN	2
11	10N-1740	CLINCH NUT 1/4 MS21042-4	2
12	10T-1133	SPACER AL .5 * .095 * 1.42	1
13	10N-1750	CLINCH NUT 5/16 MS21042-5	1
CONTROL BAR LEG OPTIONS DEPENDING ON SIZE			
9	40G-1310	LEG AT 60 STREAMLINE	2
	40G-1320	LEG AT 62 STREAMLINE	
	40G-1335	LEG AT 65 STREAMLINE	
	40G-1345	LEG AT 68 STREAMLINE	

WALLS WING

500 BLUERIDGE AVE • ORANGE • CA • 92665 • PH/FAX (714) 998-6359 / 998-0647

TITLE:

DOCUMENT ID:

DWG ID:

ISO_FALC.DWG

DRAWN:

R 04-29-97 SP

Falcon Streamline Control Bar

ID	PART NO	DESCRIPTION	QNT
FALCON ALL MODELS			
1	10A-2261	BOLT AM4-26A	3
2	40P-2301	WIRE TOP FRONT BALL SMEDG 3/32	0
5	20C-1611	NOSEPLATE HARRIER THRU CURRENT	2
6	15B-2012	ENDCAP 2 .049	2
8	10N-1740	CLINCH NUT 1/4 MS21042-4	4
9	20G-2901	COLLAR KEYHOLE TANG BOLT	1
10	10A-2321	BOLT AM4-32A	1
18	10U-1141	WASHER STEEL AN960-416L	4
7	10U-1140	WASHER STEEL AN960-416	3
FALCON 195, 225 ONLY			
17	15B-2012	ENDCAP 2 .049	1
19	10U-1140	WASHER STEEL AN960-416	2
FALCON 140, 170 ONLY			
16	15F-1404	STAND-OFF 1/4	4
17	15B-1612	ENDCAP 1 3/4 .049	1
KEYHOLE LOCK ASSEMBLY, ALL FALCONS			
11	10N-1730	CLINCH NUT 3/16 MS20142-3	1
12	10U-8010	WASHER WAVE KEYHOLE ANCHOR	1
13	20C-1501	SAFETY ALUM KEYHOLE ANCHOR	1
15	10L-1061	SCREW PAN 3/16 MS35207-263	1

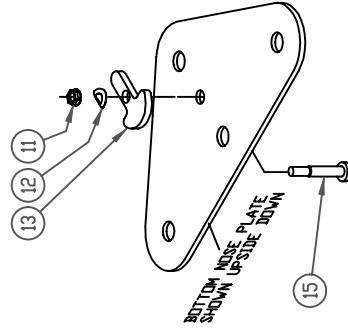
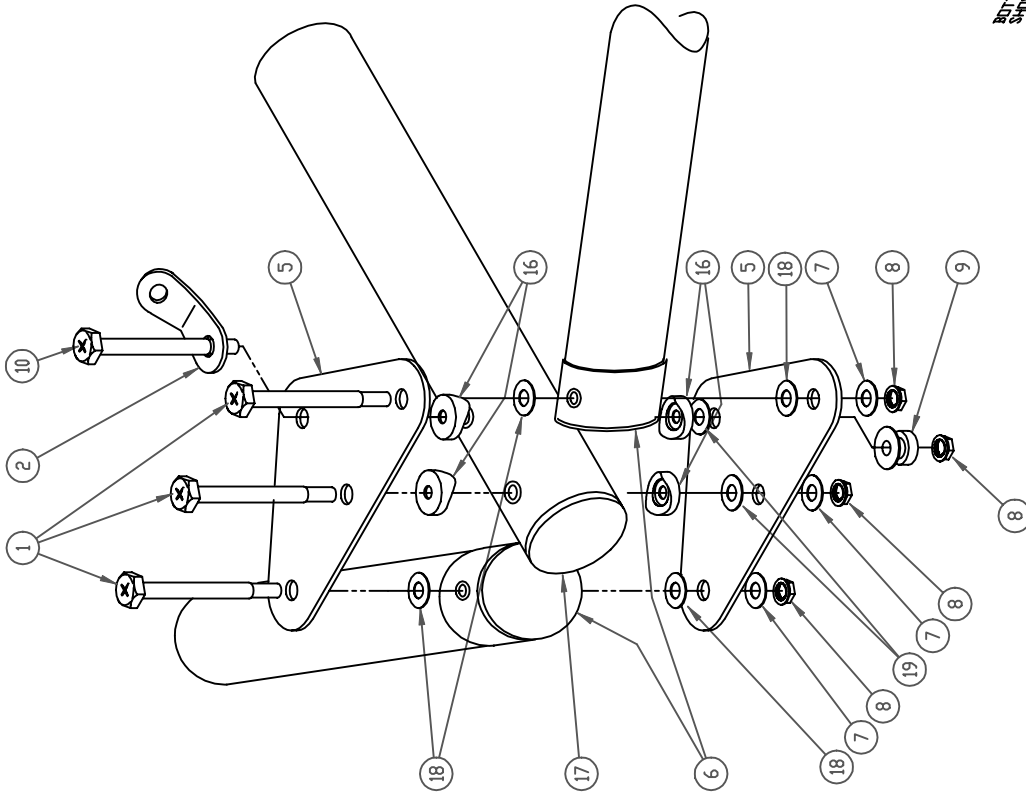

WALLS WING

500 BLUERIDGE AVE • ORANGE • CA • 92665 • PH/FAX (714) 998-6359 / 998-0647

TITLE:

DOCUMENT ID:
75E035

DWG ID:
ISO_FALC.DWG

DRAWN:
R 09-15-98 SP

Falcon Noseplate Assembly

ID	PART NO	DESCRIPTION	QNT
195			
1	10A-2311	BOLT AN4-31A	1
2	10N-1740	CLINCH NUT 1/4 MS21042-4	2
3	20A-1601	BRACKET, KEYHOLE TYPE LAYFLAT	1
4	NA	PERLON 4mm HANDLE	1
5	20G-2901	COLLAR KEYHOLE TANG BOLT	1
6	10R-0342	RIVET AL 1/8 * .25	1
7	15B-2012	ENDCAP 2 .049	1
8	20E-2321	TANG 1 HOLE 2 SLOT 5/8 WEBBING	1
9	40P-3301	WIRE SET BOTTOM REAR BALL SWDG	0
10	10U-1140	WASHER STEEL AN960-416	1
11	10C-5121	BOLT NAS 623-4-12	1
140, 170 ONLY.	INCLUDE NO. 2-6,8-11 FROM 195 DIAGRAM		
12	15F-1602	STAND-OFF 1/8	1
13	10A-2271	BOLT AN4-27A	1
15	15C-4209	ENDCAP 42mm OD 40.2 ID	1
225 ONLY.	INCLUDE NO. 2-6-10 FROM 195 DIAGRAM		
16	10A-2331	BOLT AN4-33A	1
17	20G-2902	COLLAR 2 KEYHOLE TANG BOLT	1
18	15F-1404	STAND-OFF 1/4	1

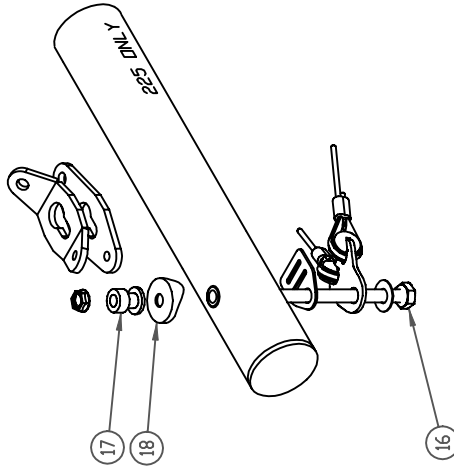
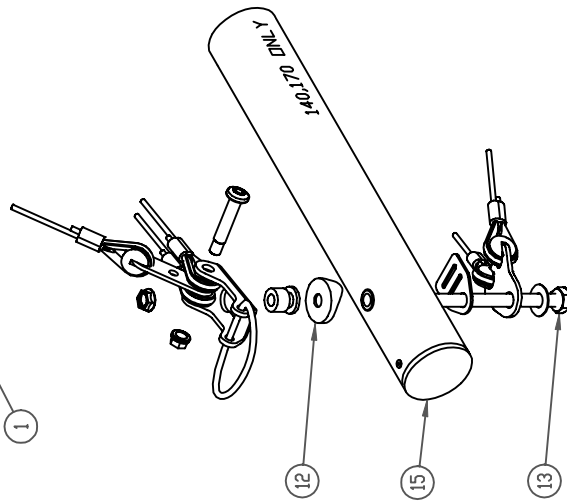
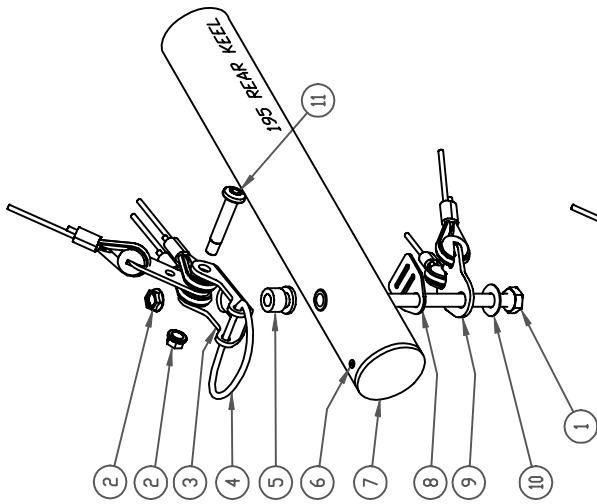

TITLE:

Falcon Rear Keel

DOCUMENT ID:
75E044

DWG ID:
150_FALC.DWG

DRAWN:
R 04-29-97 SP

WALLS WING

500 BLUERIDGE AVE. • ORANGE • CA • 92665 • PH/FAX (714) 998-6359 / 998-0647

ID	PART NO	DESCRIPTION	QNT
1	10M-1361	SCREW 6/32 FLSTR MACH HEAD SS	1
2	15J-1501	CAP AT KINGPOST TOP POLYCARB	1
3	40P-2301	WIRE TOP FRONT BALL SWEDG 3/32	1
4	20G-2323	KINGPOST TOP INSERT AT ALUM	1
5	40P-2202	WIRE TOP SIDE BALL SWEDGE 3/32	2
6	15J-1502	TOP AT KINGPOST POLYCARB	1
7	40P-2401	WIRE TOP REAR BALL SWEDG 3/32	1
8	40P-4101	WIRE BRIDLE PIGTAIL	1
9	10R-0342	RIVET AL 1/8 * .25	2
10	10N-1740	CLINCH NUT 1/4 MS21042-4	2
11	20A-1214	BRACKET, KP BASE KP HANG	1
12	10C-5201	BOLT NAS 623-4-20	1
REPLACES NO. 10 and 12			
13	10R-0449	RIVET AL 1/4 * 1.375 SOLID	1
140, 170, 195 ONLY			
14	40K-1321	KINGPOST STRM LF NO VG	1
225 ONLY			
15	40K-1322	KINGPOST STRM LF NO VG W/SLV	1

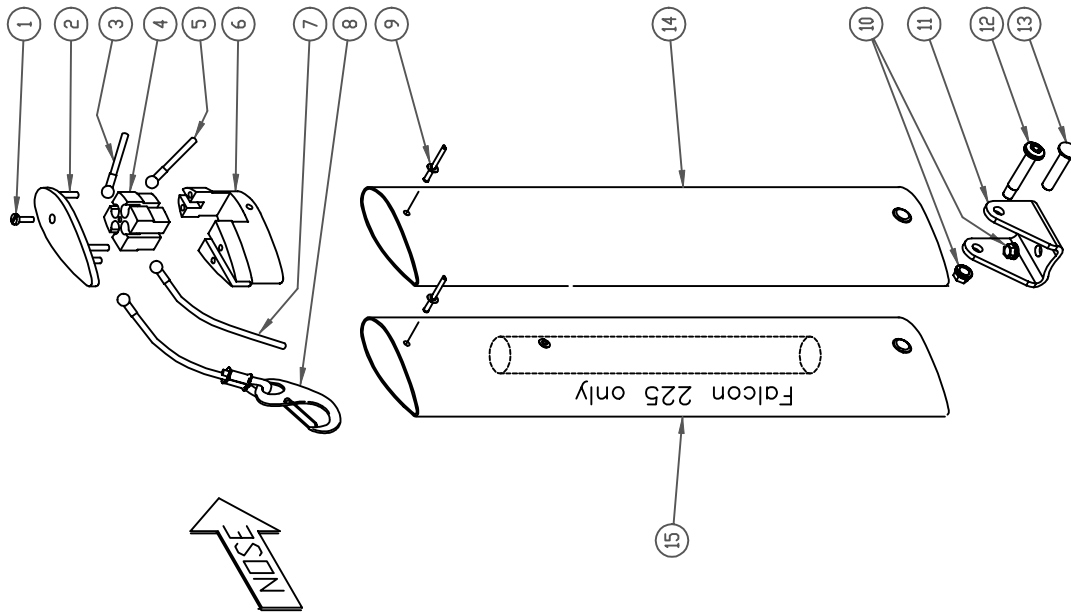

Falcon Kingpost Assembly

TITLE:

DRAWN:
R 04-29-97 SP

DWG ID:
150_FALC.DWG

DOCUMENT ID:
75E052



500 BLUERIDGE AVE • ORANGE • CA • 92665 • PH/FAX (714) 998-6359 / 998-0647

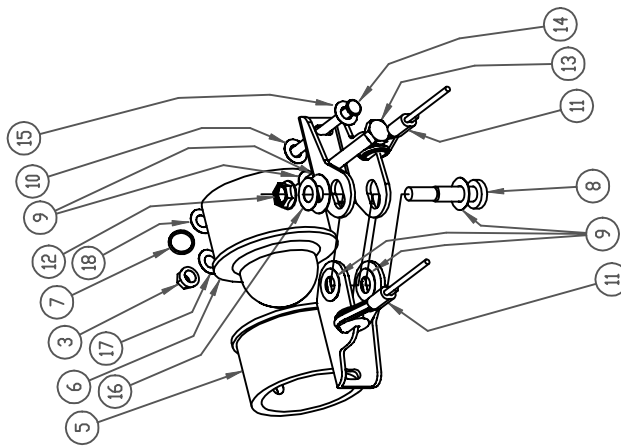
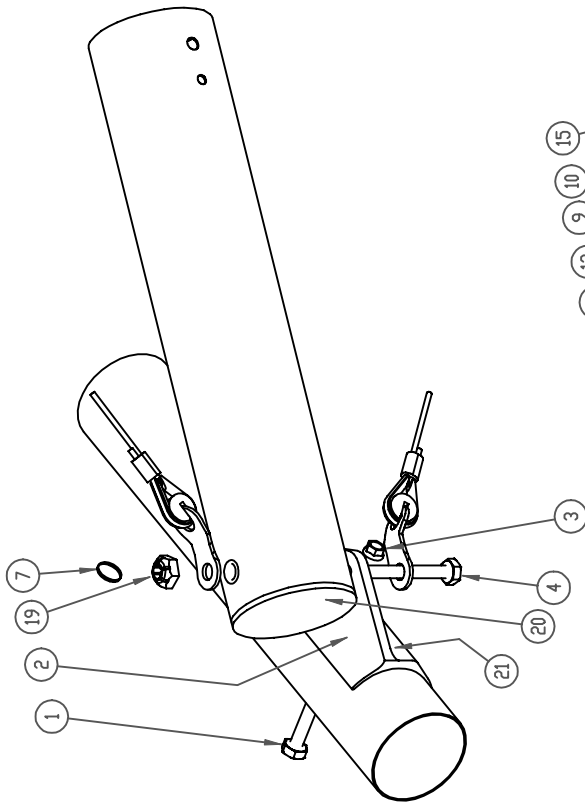

ID	PART NO	DESCRIPTION	QNT
COMMON PARTS - ALL MODELS			
1	10B-2400	BOLT AN24-40	2
2	206-1110	XBAR/LE BRACKET 52MM LDMG EDGE	2
3	10N-1740	CLINCH NUT 1/4 MS21042-4	4
7	10P-1100	SAFETY RING AN 9491 SMALL	4
8	10C-6171	BOLT NAS 623-5-17	1
9	10U-5125	WASHER NYLON .75 * .316 * .020	6
10	10U-5093	WASHER NYLON .560 * .192 * .015	2
11	40P-4204	WIRE XBAR SWEEP CNTR HINGE SET	1
12	10N-1750	CLINCH NUT 5/16 MS21042-5	1
15	10U-2093	WASHER STEEL .560 * .19 * .050	2
16	10U-1151	WASHER STEEL AN960-516L	1
19	10N-1340	CASTLE NUT 1/4 AN310-4	2
21	10R-0366	RIVET AL 3/16 * .375 CHAAP06-4	4
Falcon 195, 225			
4	10A-2320	BOLT AM4-32	2
5	15J-2110	SOCKET XBAR CNTR BALL JOINT 62	1
6	15J-2120	BALL -XBAR CNTR BALL JOINT 62	1
13	10A-2261	BOLT AM4-26A	2
14	10G-1830	CLEVIS PIN MS20392-2C83	2
20	15C-6219	ENDCAP 62mm OD 58.2 ID	2
Falcon 140, 170			
4	10A-2260	BOLT AM4-26	2
5	15J-2112	SOCKET XBAR CNTR BALL JOINT 52	1
6	15J-2122	BALL -XBAR CNTR BALL JOINT 52	1
13	10A-2231	BOLT AM4-23A	2
14	10G-1710	CLEVIS PIN MS20392-2C71	2
17	10U-1140	WASHER STEEL AN960-416	2
18	10U-1130	WASHER STEEL AN960-10	2
20	15B-2013	ENDCAP 2" MULTIGAUGE	2

Falcon Crossbar Assembly

TITLE:

DRAWN: R 09-15-98 SP

DWG ID: ISO_FALC.DWG

DOCUMENT ID: 75E064



500 BLUERIDGE AVE • ORANGE • CA • 92665 • PH/FAX (714) 998-6359 / 998-0647

ID	PART NO	DESCRIPTION	QNT
REAR LEADING EDGE			
1	10L-1061	SCREW PAN 3/16 MS35207-263	2
2	20G-2411	WASHOUT RECEPTACLE AT ALUM	2
3	10U-8020	WASHER STEEL EXTRNL TOOTH #10	2
4	10N-1130	NYLOCK LOMPRO 3/16 MS21083-N03	2
5	10G-4210	CLEVIS PIN STEEL 3C77 REPLACE	2
6	10N-1940	PUSHNUT 1/4 INCH	4
7	10U-1400	WASHER MS 15795-210	2
8	10P-1100	SAFETY RING AN 9491 SMALL	4
9	40M-1321	SHIM KIT ALL 7075 MODELS 50mm	2
28	10G-1650	CLEVIS PIN MS20392-2C65	2
SAIL PLUG ASSEMBLY			
10	10N-1120	NYLOCK LOMPRO 1/8 MS21083-N06	2
11	10T-1101	SPACER AL .187 * .022 * .125	2
12	10L-1041	SCREW PAN 1/8 MS35206-228	2
13	15J-1901	ENDCAP SLOTTED SAIL MOUNT PC	2
14	10R-0342	RIVET AL 1/8 * .25	2
15	40M-1211	SAIL PLUG ALL 7075 MODELS 50mm	2
ADJUSTABLE SAIL PLUG. REPLACES SAIL PLUG ASSY NO. 10-15			
16	15J-1911	ENDCAP SAIL MOUNT ADJUSTABLE	2
17	15J-1912	LOCKING SLIDE ADJUST ENDCAP	2
18	10S-1101	C-CLIP SAIL ADJUSTER CAP SCREW	2
19	10K-2026	SCREW SOCKET CAP 10-32*1.75 SS	2
20	70G-4019	PLACARD - SAIL ADJUSTER ALIGN	2
29	10U-1130	WASHER STEEL AN960-10	2
WASHOUT TIP			
21	15B-0612	ENDCAP 3/4 .049	2
22	10R-0342	RIVET AL 1/8 * .25	2
23	40M-1141	WASHOUT TUBE-CLIP RETAIN 6061	2
24	20A-1501	BUTTON SPRING SINGLE - W/O TIP	2
25	10U-1140	WASHER STEEL AN960-416	2
26	10U-1141	WASHER STEEL AN960-416L	2

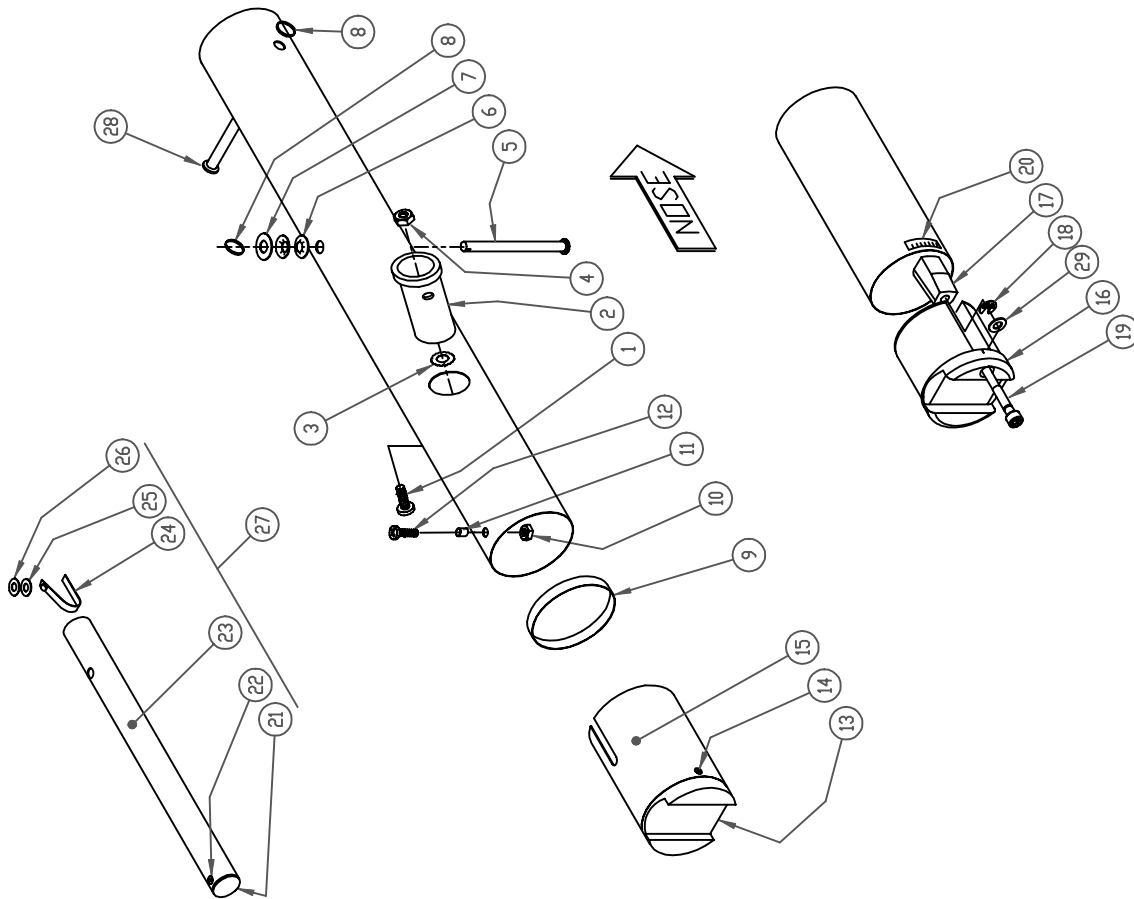

Falcon Rear Leading Edge, Sail Adjuster, WO Tip

TITLE:

DWG ID: ISO_FALC.DWG
DRAWN: R 09-15-98 SP

DOCUMENT ID: 75E074



500 BLUERIDGE AVE • ORANGE • CA • 92665 • PH/FAX (714) 998-6359 / 998-0647

Item	Part No	Description	Qty
1	10A-2140	AM4-14	2
2	10C-2291	NAS517-4-29	1
3	10C-5111	NAS623-4-11	2
4	10C-5131	NAS623-4-13	2
5	10G-1370	MS20392-2C37	2
6	10G-2370	MS20392-3C37	2
7	10G-3610	MS20392-4C61	1
8	10N-1445	SPEEDNUT 1/4 X 28	2
9	10N-1740	CLINCH NUT 1/4 MS21042-4	5
10	10P-1100	SAFETY RING AN 9491 SMALL	5
11	10P-1200	SAFETY RING AN R2 LARGE	2
12	10U-5125	WASHER NYLON .75 X .316 X .020	3
13	15A-1401	GRIP BASETUBE POLYFOAM	2
14	20G-1402	CBAR PLUG AT LEG BOTM ROUND 95	2
15	20G-1412	CBAR PLUG AT LEG TOP ROUND	2
16	20G-1612	Bracket Keel Cntr Falcon	1
17	20G-1703	CBAR ELBOW AT TOP ROUND	2
18	20G-1801	CBAR BRACKET AT BASETUBE END	2
19	40F-13nn	BASE TUBE AT STRAIGHT (SEE TABLE)	1
20	40G-12nn	LEG AT ROUND (SEE TABLE)	2
21	40P-3103	WIRE BOTTM SIDE 3/32 AT STYLE	2
22	40P-3201	WIRE SET BOTTM FRONT BALL SWG	1
23	40P-3301	WIRE SET BOTTM REAR BALL SWG	1

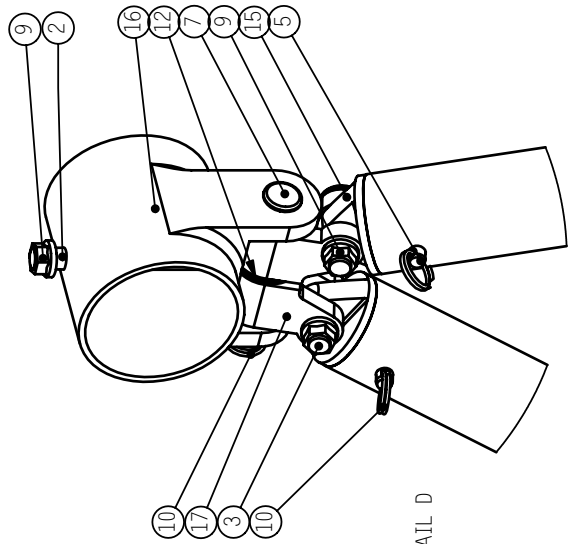

DETAIL D

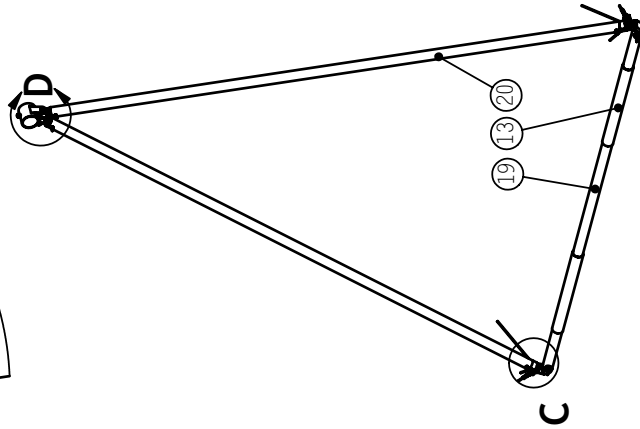

DETAIL C

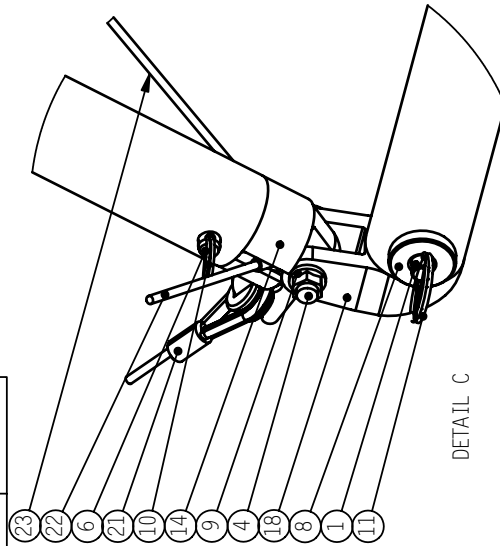

TITLE: **Falcon 2 AT Round Control Bar**

REV/STON: **C**

BY: **PEARSON**

STATUS:

REVISED: **4/15/2005**

DRAWN: **9/22/2003**

DOCUMENT ID:

AT Control Bar Round

SLD/DF ID:

500 BLUERIDGE AVE • ORANGE, CA 92865 • PH/FAX (714) 998-6359 / 998-0647

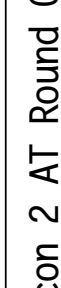

Item	Part No	Description	Qty
1	10A-2140	AM4-14	2
2	10A-3251	AN5-25A	1
3	10C-2291	NAS517-4-29	1
4	10C-5111	NAS623-4-11	2
5	10C-5131	NAS623-4-13	2
6	10G-1330	MS20392-2C33	4
7	10N-1250	LOCKNUT LOWPRO 5/16 AN364-5	1
8	10N-1445	SPEEDNUT 1/4 X 28	2
9	10N-1740	CLINCH NUT 1/4 MS21042-4	5
10	10P-1100	SAFETY RING AN 9491 SMALL	4
11	10P-1200	SAFETY RING AN R2 LARGE	2
12	10T-1133	SPACER AL .5 X .083 X 1.42	1
13	10U-5125	WASHER NYLON .75 X .316 X .020	2
14	15A-1401	GRIP BASETUBE POLYFOAM	2
15	20G-1425	CBAR PLUG AT LEG BOT STR 97 LEFT	1
16	20G-1426	CBAR PLUG AT LEG BOT STR 97 RIGHT	1
17	20G-1433	CBAR PLUG AT LEG TOP STR TOEIN	2
18	20G-1612	Bracket Keel Cntr Falcon	1
19	20G-1712	CBAR ELBOW AT TOP STREAM	2
20	20G-1801	CBAR BRACKET AT BASETUBE END	2
21	40F-13mm	BASE TUBE AT SPEEDBAR (SEE TABLE)	1
22	40G-13mm	LEG AT STREAMLINE (SEE TABLE)	2
23	40P-3103	WIRE BOTTOM SIDE 3/32 AT STYLE	2
24	40P-3201	WIRE SET BOTTM FRONT BALL SWG	1
25	40P-3301	WIRE SET BOTTOM REAR BALL SWG	1

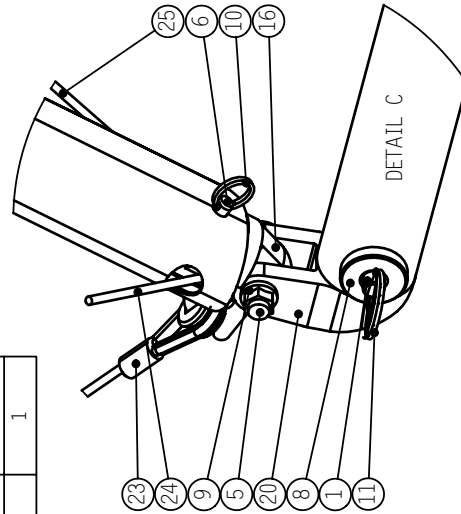
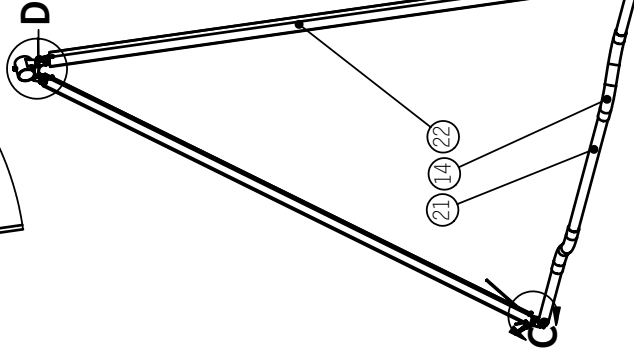
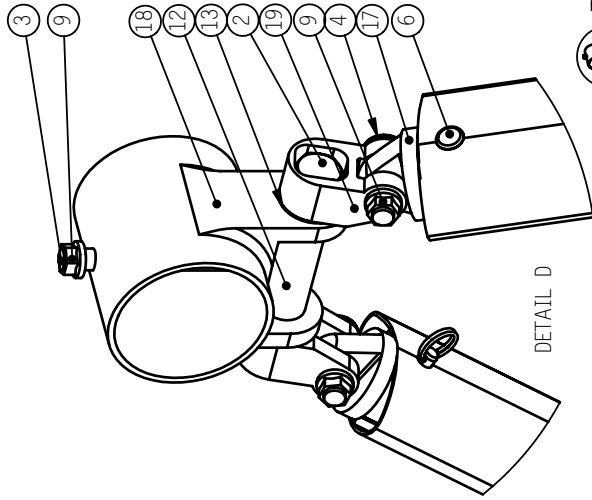

500 BLUERIDGE AVE • ORANGE, CA 92865 • PH/FAX (714) 998-6359 / 998-0647

TITLE: **Falcon 2 AT Streamline Control Bar**

REVISION: **C**

SLDWF ID: **AT Control Bar Streamline**

DOCUMENT ID:

DRAWN: **9/22/2003**

REVISED: **4/15/2005**

STATUS:

BY: **PEARSON**

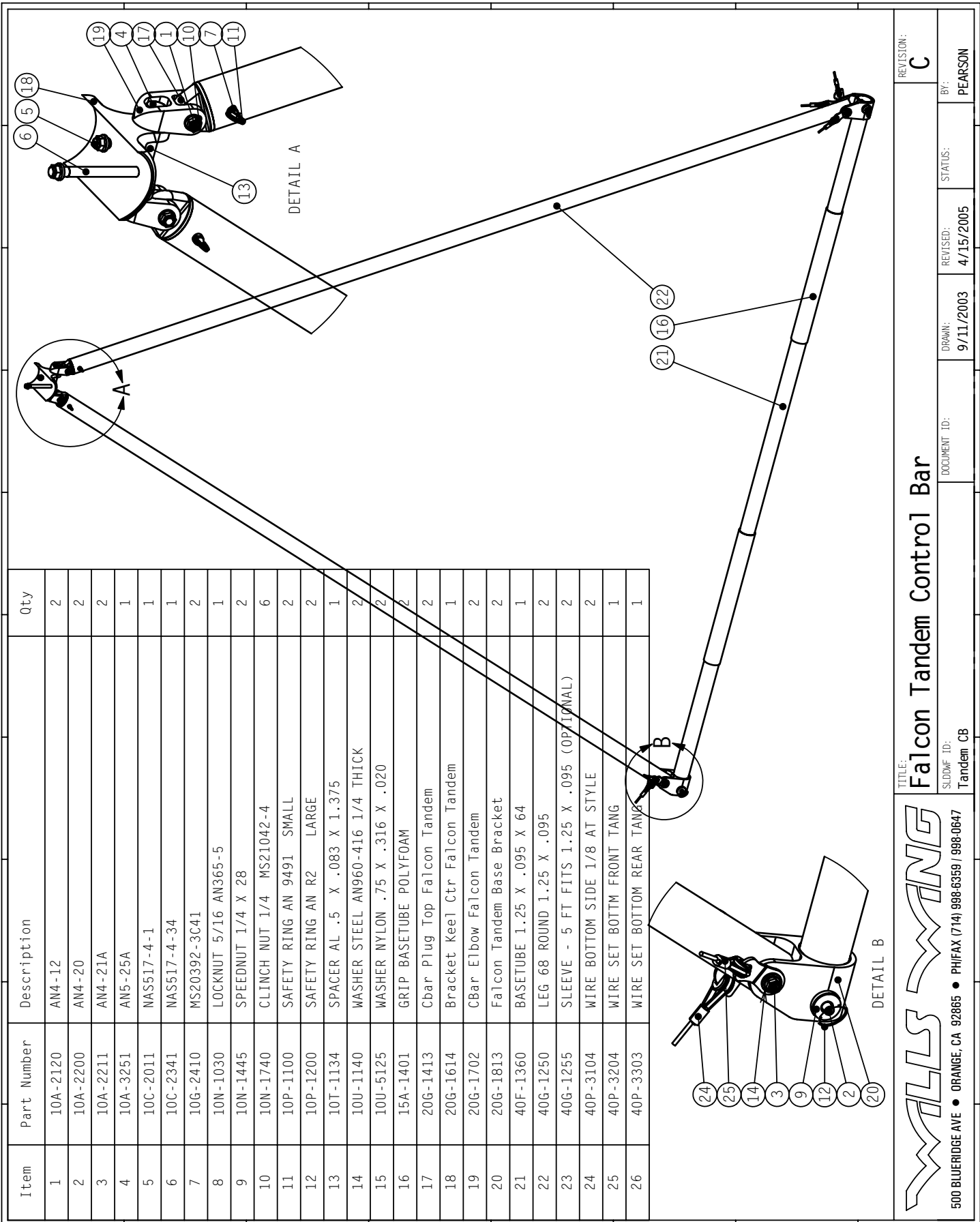

Item	Part Number	Description	Qty
1	10A-2120	AM4-12	2
2	10A-2200	AM4-20	2
3	10A-2211	AM4-21A	2
4	10A-3251	AM5-25A	1
5	10C-2011	NAS517-4-1	1
6	10C-2341	NAS517-4-34	1
7	10G-2410	MS20392-3C41	2
8	10N-1030	LOCKNUT 5/16 AN365-5	1
9	10N-1445	SPEEDNUT 1/4 X 28	2
10	10N-1740	CLINCH NUT 1/4 MS21042-4	6
11	10P-1100	SAFETY RING AN 9491 SMALL	2
12	10P-1200	SAFETY RING AN R2 LARGE	2
13	10T-1134	SPACER AL .5 X .083 X 1.375	1
14	10U-1140	WASHER STEEL AN960-416 1/4 THICK	2
15	10U-5125	WASHER NYLON .75 X .316 X .020	2
16	15A-1401	GRIP BASETUBE POLYFOAM	2
17	20G-1413	Cbar Plug Top Falcon Tandem	2
18	20G-1614	Bracket Keel Ctr Falcon Tandem	1
19	20G-1702	CBar Elbow Falcon Tandem	2
20	20G-1813	Falcon Tandem Base Bracket	2
21	40F-1360	BASETUBE 1.25 X .095 X 64	1
22	40G-1250	LEG 68 ROUND 1.25 X .095	2
23	40G-1255	SLEEVE - 5 FT FITS 1.25 X .095 (OPTIONAL)	2
24	40P-3104	WIRE BOTTOM SIDE 1/8 AT STYLE	2
25	40P-3204	WIRE SET BOTTM FRONT TANG	1
26	40P-3303	WIRE SET BOTTOM REAR TANG	1

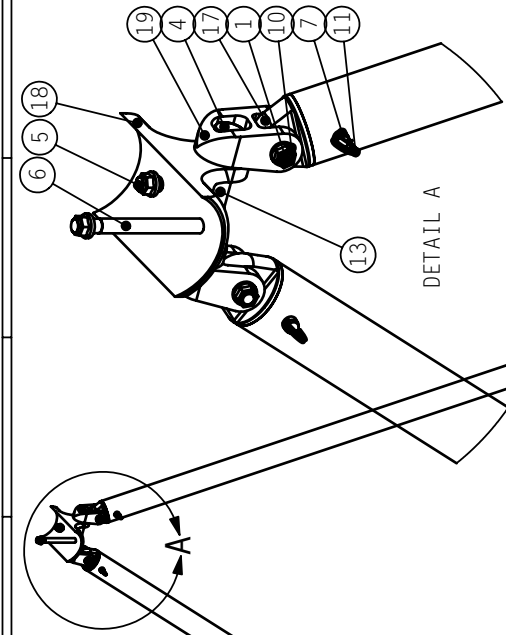
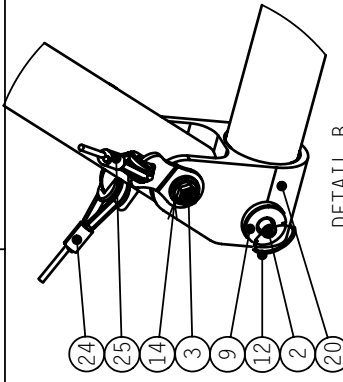

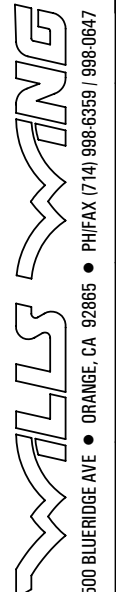
 500 BLUERIDGE AVE • ORANGE, CA 92865 • PH/FAX (714) 998-6359 / 998-0647

TITLE: **Falcon Tandem Control Bar**
 SLDDMF ID: **Tandem CB**

DOCUMENT ID: _____
 DRAWN: 9/11/2003
 REVISED: 4/15/2005
 STATUS: _____
 BY: PEARSON
 REVISION: **C**

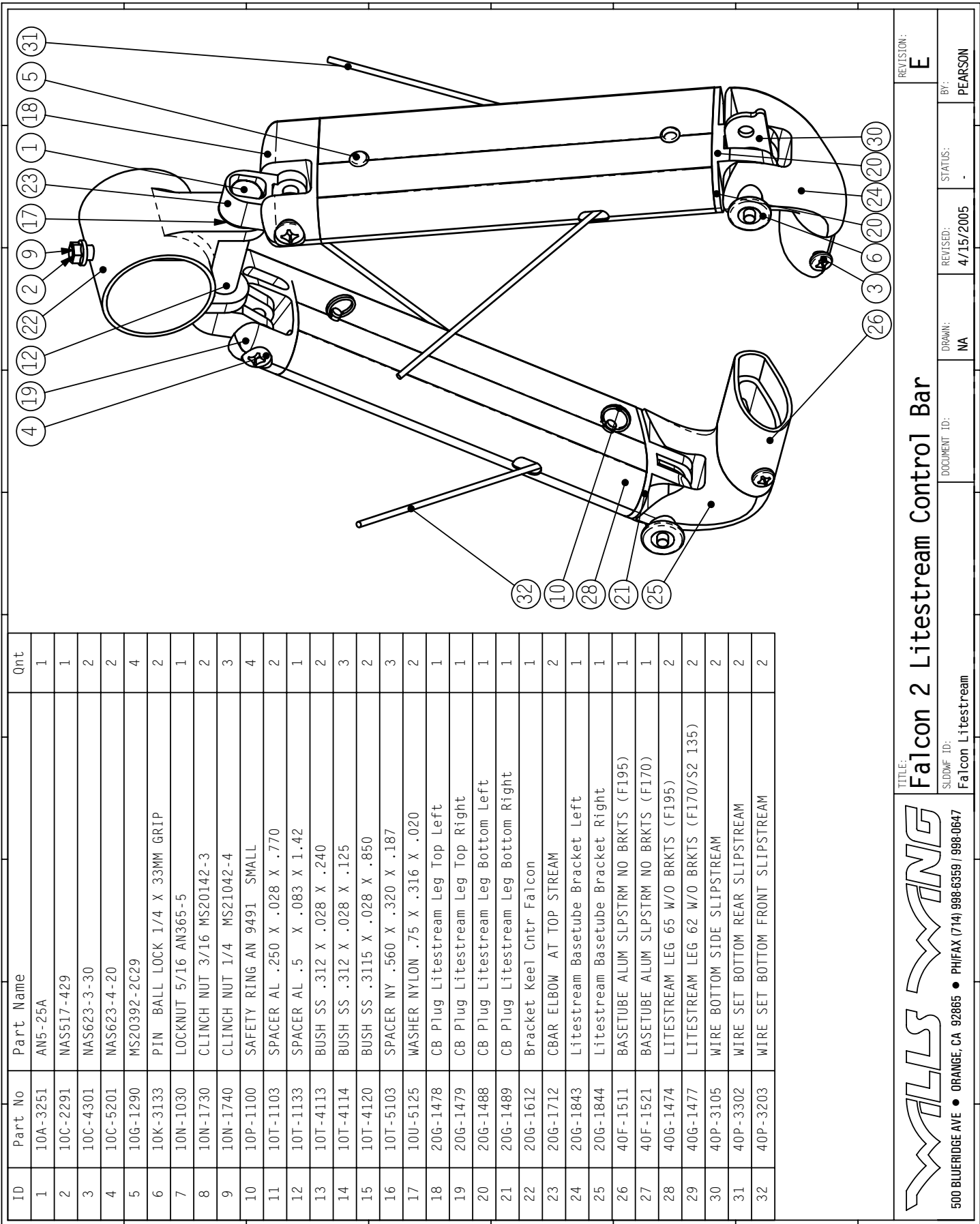

ID	Part No	Part Name	Qnt
1	10A-3251	AN5-25A	1
2	10C-2291	NAS517-429	1
3	10C-4301	NAS623-3-30	2
4	10C-5201	NAS623-4-20	2
5	10G-1290	MS20392-2C29	4
6	10K-3133	PIN BALL LOCK 1/4 X 33MM GRIP	2
7	10N-1030	LOCKNUT 5/16 AN365-5	1
8	10N-1730	CLINCH NUT 3/16 MS20142-3	2
9	10N-1740	CLINCH NUT 1/4 MS21042-4	3
10	10P-1100	SAFETY RING AN 9491 SMALL	4
11	10T-1103	SPACER AL .250 X .028 X .770	2
12	10T-1133	SPACER AL .5 X .083 X 1.42	1
13	10T-4113	BUSH SS .312 X .028 X .240	2
14	10T-4114	BUSH SS .312 X .028 X .125	3
15	10T-4120	BUSH SS .3115 X .028 X .850	2
16	10T-5103	SPACER NY .560 X .320 X .187	3
17	10U-5125	WASHER NYLON .75 X .316 X .020	2
18	20G-1478	CB Plug Litestream Leg Top Left	1
19	20G-1479	CB Plug Litestream Leg Top Right	1
20	20G-1488	CB Plug Litestream Leg Bottom Left	1
21	20G-1489	CB Plug Litestream Leg Bottom Right	1
22	20G-1612	Bracket Keel Cntr Falcon	1
23	20G-1712	CBAR ELBOW AT TOP STREAM	2
24	20G-1843	Litestream Basetube Bracket Left	1
25	20G-1844	Litestream Basetube Bracket Right	1
26	40F-1511	BASETUBE ALUM SLPSTRM NO BRKTS (F195)	1
27	40F-1521	BASETUBE ALUM SLPSTRM NO BRKTS (F170)	1
28	40G-1474	LITESTREAM LEG 65 W/O BRKTS (F195)	2
29	40G-1477	LITESTREAM LEG 62 W/O BRKTS (F170/S2 135)	2
30	40P-3105	WIRE BOTTOM SIDE SLIPSTREAM	2
31	40P-3302	WIRE SET BOTTOM REAR SLIPSTREAM	2
32	40P-3203	WIRE SET BOTTOM FRONT SLIPSTREAM	2

WALLS WANG
 500 BLUERIDGE AVE • ORANGE, CA 92865 • PH/FAX (714) 998-6359 / 998-0647

TITLE: **Falcon 2 Litestream Control Bar**
 SLD/DMF ID: **Falcon Litestream**

DOCUMENT ID: **NA**
 REVISED: **4/15/2005**
 STATUS: **-**
 BY: **PEARSON**

REV/STON: **E**

ITEM	Part No	Description	Falcon II/QTY.
1	20C-1639	NPLATE 2003 ASSY W/KHOLE BUTN LOC	1
2	10U-1141	WASHER STEEL AN960-416 1/4 THIN	4
3	10T-5103	SPACER NY .560 X .320 X .187	4
4	40P-3201	WIRE SET BOTTM FRONT BALL SWG	1
5	10N-1740	CLINCH NUT 1/4 MS21042-4	3
6	20C-1638	NOSEPLATE UNIVERSAL 2003	1
7	10A-2301	AM4-30A	1
8	10A-2261	AM4-26A	3
9	40P-2301	WIRE TOP FRONT BALL SWEDG 3/32	1
10	20G-2905	KEYHOLE COLLAR NUT ASSY	1

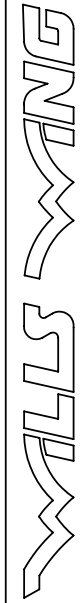
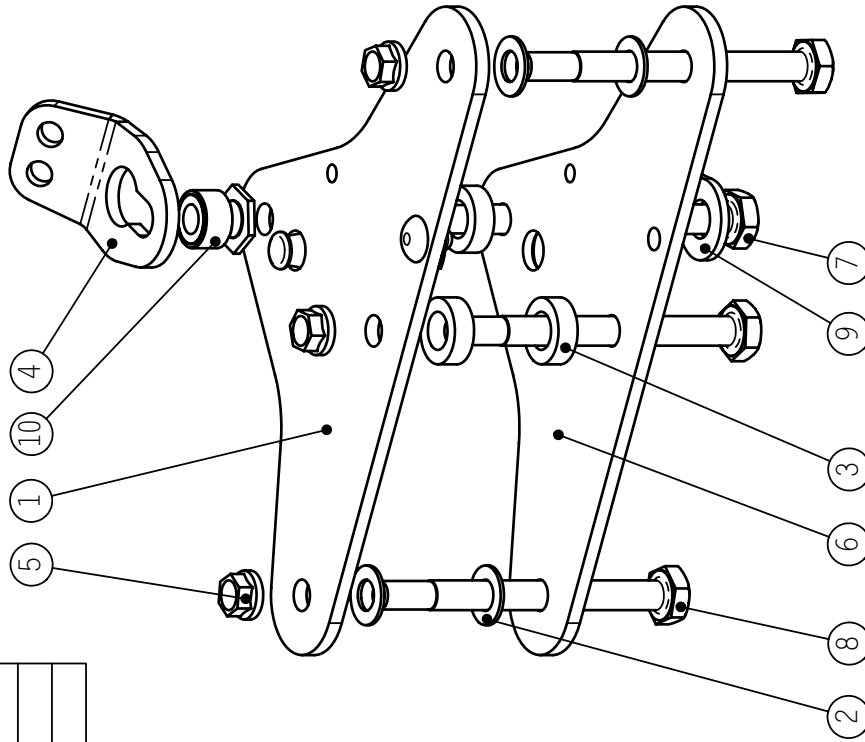

500 BLUERIDGE AVE • ORANGE, CA 92865 • PH/FAX (714) 998-6359 / 998-0647

TITLE:
Falcon 2 Noseplate Assembly

REVISION:
A

SLODINF ID:
Falcon noseplate.A

DRAWN:
9/22/2003

STATUS:

BY:
PEARSON

Item	Part Number	Description	Falcon 2 140	Falcon 2 170	Falcon 2 195	Falcon 2 225	Falcon Tandem
1	10U-5125	WASHER NYLON .75 X .316 X .020	4	4	4	4	4
3	15J-2122	BALL XBAR CNTR BALL JNT 52	1	1	-	-	-
3	15J-2126	BALL XBAR CNTR BALL JNT 2.25	-	-	1	-	-
3	15J-2131	BALL XBAR CNTR BALL JNT 2.5	-	-	-	1	-
3	15J-2133	BALL XBAR CNTR BALL JNT 2.5 X 058	-	-	-	-	1
4	15J-2112	SOCKET XBAR CNTR BALL JNT 52	1	1	-	-	-
4	15J-2116	SOCKET XBAR CNTR BALL JNT 2.25	-	-	1	-	-
4	15J-2118	SOCKET XBAR CNTR BALL JNT 2.5	-	-	-	1	-
4	15J-2119	SOCKET XBAR CNTR JNT 2.5 X 058	-	-	-	-	1
6	10C-4081	NAS623-3-8	2	2	2	2	2
7	10C-5071	NAS623-4-7	2	2	2	2	2
9	10N-1730	CLINCH NUT 3/16 MS20142-3	2	2	2	2	2
10	10N-1740	CLINCH NUT 1/4 MS21042-4	2	2	2	2	2
11	10U-1130	WASHER STEEL AN960-10	4	4	4	4	4
12	10U-1140	WASHER STEEL AN960-416 1/4 THICK	2	2	2	2	2
14	10C-5181	NAS623-4-18	1	1	1	1	1
15	10U-4100	WASHER BRASS .625X .281X .04	4	4	4	4	4
16	10N-0040	LOCKNUT LOW PRO 52N/TE-048	1	1	1	1	1

Note orientation of hinge brackets
Right wing over left wing

Hinge bracket assembly configuration for
Falcon 2s produced July 2005 and later.
See Advisory TB20050621 for earlier configurations

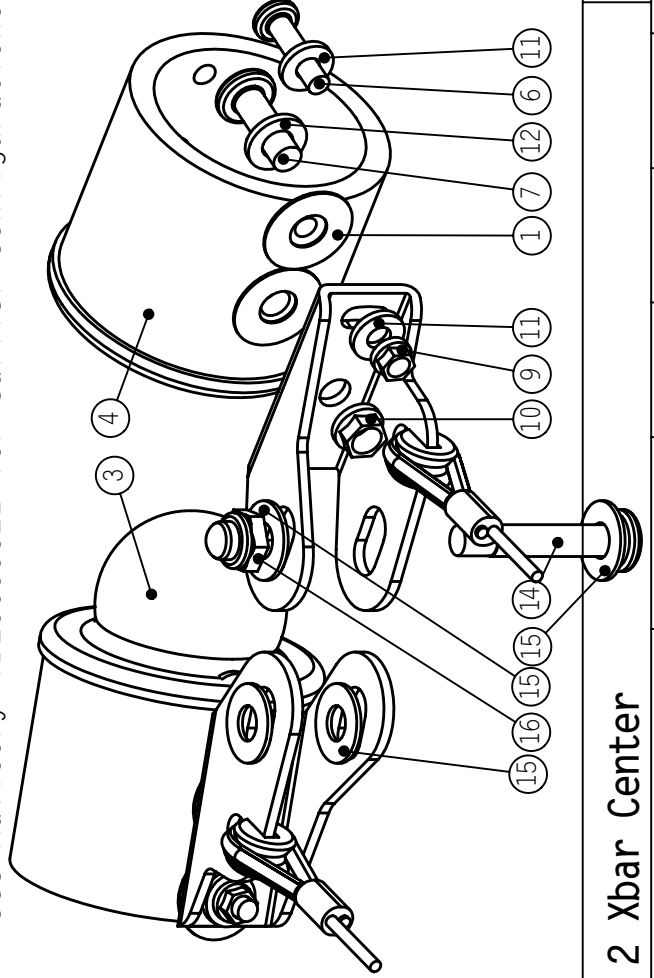

Item	Part Number	Description	Falcon 2 140	Falcon 2 170	Falcon 2 195	Falcon 2 225	Falcon Tandem
1	10A-2260	AM4-26	1	1	-	-	-
1	10A-2320	AM4-32	-	-	-	1	1
2	10A-2300	AM4-30	-	-	1	-	-
3	10G-1650	MS20392-2C65	1	1	1	1	1
4	10K-2031	SCREW SOCKET CAP SS 1/4x28x5/8	1	1	1	1	1
5	10N-1340	CASTLE NUT 1/4 AN310-4	1	1	1	1	1
6	10N-1740	CLINCH NUT 1/4 MS21042-4	1	1	1	1	1
7	10P-1100	SAFETY RING AN 9491 SMALL	2	2	2	2	2
8	10R-0366	RIVET AL 3/16 X .375 CHAAPQ6-4	2	2	2	2	2
9	15B-2013	ENDCAP 2.0 IN MULTIGAUGE	1	1	-	-	-
9	15B-1213	ENDCAP 2.25 IN MULTIGAUGE	-	-	1	-	-
9	15C-6219	ENDCAP 62mm OD 58.2 ID	-	-	-	1	1
10	20G-1110	XBAR/LE BRACKET 52MM LDNG EDGE	1	1	1	1	1
11	40P-2202	WIRE TOP SIDE BALL SWG 1/8	1	1	1	1	-
11	40P-2203	WIRE TOP SIDE BALL SWG 1/8	-	-	-	-	1
12	40P-3103	WIRE BOTTOM SIDE 3/32 AT STYLE	1	1	1	1	-
12	40P-3104	WIRE BOTTOM SIDE 1/8 AT STYLE	-	-	-	-	1

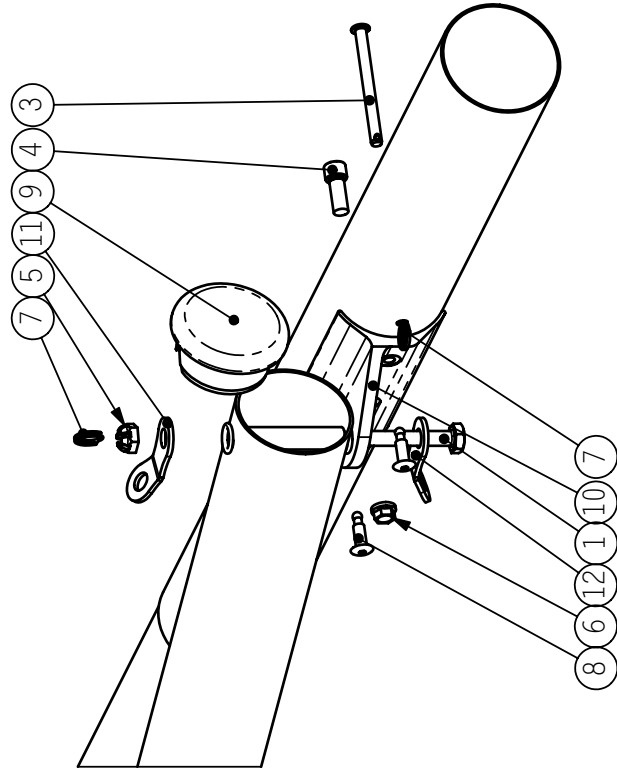

WALLS WANG
500 BLUERIDGE AVE • ORANGE, CA 92865 • PH/FAX (714) 998-6359 / 998-0647

TITLE: **Falcon 2 Xbar LE Junction**

PART NO: **NA**
REVISION: **B**
DRAWN: 9/22/2003
REVISED: 4/18/2005
STATUS: **PEARSON**

T.U.S. .X ± .05
.XX ± .015
.XXX ± .003
.XXXX ± .0005
ANGLES ± 1/2°

ITEM	Part No	Description	QTY.
2	10G-2750	MS20392-3C75	1
3	10K-2026	SCREW SOCKET CAP 10-32X1.75 SS	1
4	10L-1061	SCREW PAN 3/16 MS35207-263	1
5	10N-1130	LOCKNUT LOWPRO 3/16 AN364-3	1
6	10N-1940	PUSHNUT 1/4 INCH	2
7	10P-1200	SAFETY RING AM R2 LARGE	1
8	10R-0342	RIVET AL 1/8 X .25	1
9	10S-1101	C-CLIP SAIL ADJUSTER CAP SCREW	1
10	10U-1130	WASHER STEEL AN960-10	1
11	10U-1400	WASHER MS 15795-210	1
12	15B-0608	ENDCAP 3/4 MULTIGAUGE	1
13	15J-1911	ENDCAP SAIL MOUNT ADJUSTABLE	1
14	15J-1912	LOCKING SLIDE ADJUST ENDCAP	1
15	30J-3101	BUNGEE - 1/8	1
16	20G-2411	Washout Tube Receptacle AT Alum	1
17	40M-1144	WASHOUT TUBE BUNGEE RETAIN	1
18	70G-4019	PLACARD - SAIL ADJUSTER ALIGN	1

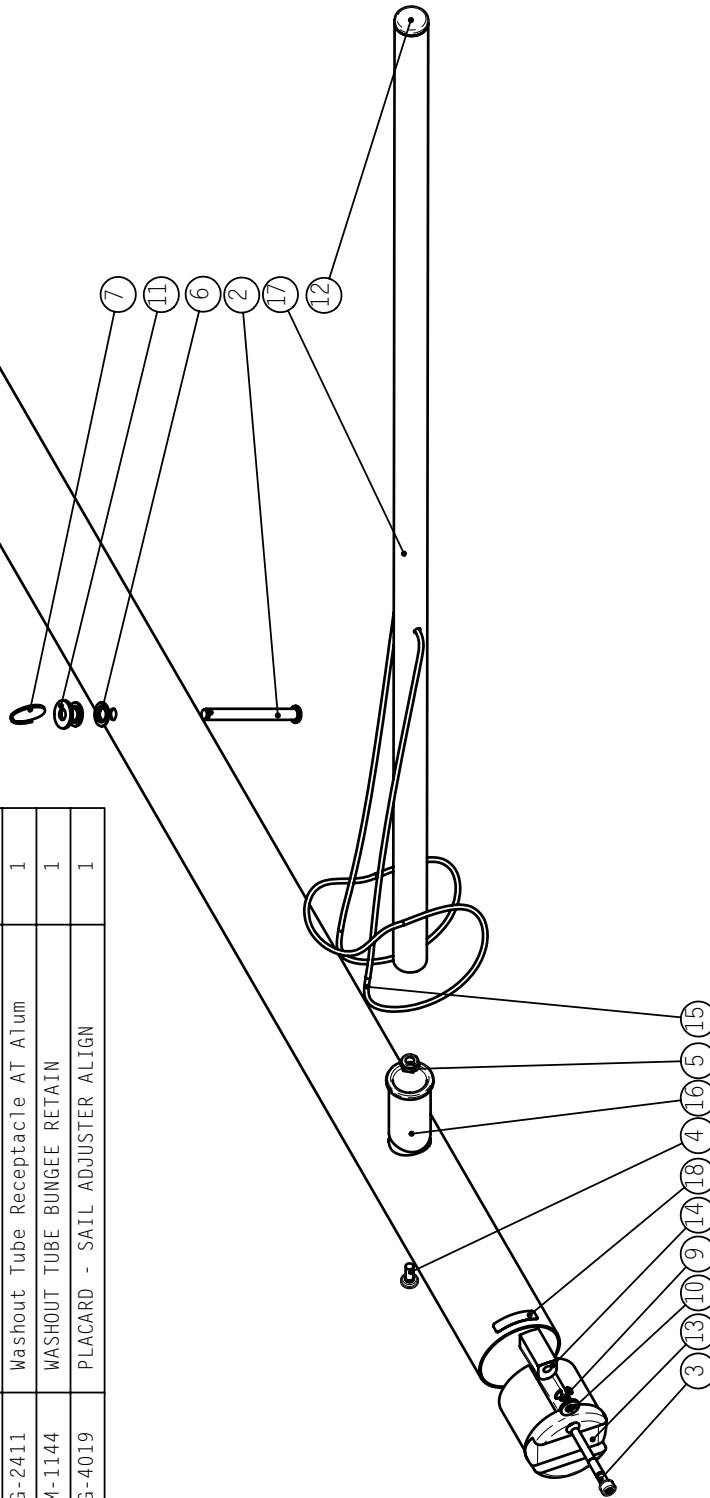

500 BLUERIDGE AVE • ORANGE, CA 92865 • PH/FAX (714) 998-6359 / 998-0647

TITLE: Falcon 2 Rear Leading Edge Assembly

REV/STON: C

SLD/DF ID: Falcon 2 Rear Leading Edge

DOCUMENT ID: 9/22/2003

REVISED: 4/18/2005

STATUS: Released

BY: PEARSON

ITEM	Part No	Description	Falcon 2/QTY.	Falcon Tandem/QTY.
1	10M-1361	SCREW 6/32 FLSTR MACH HEAD SS	1	1
2	10R-0342	RIVET AL 1/8 X .25	2	2
3	15J-1501	CAP AT KINGPOST TOP POLYCARB	1	1
4	15J-1502	TOP AT KINGPOST POLYCARB	1	1
5	20G-2323	KINGPOST TOP INSERT AT ALUM	1	-
6	20G-2324	KINGPOST TOP INSERT 1/8 WIRE	-	1
7	40K-1121	KINGPOST STRM LF NO VG	1	-
8	40K-1122	KINGPOST STRM W/SLV (F225; TANDEM)	-	1
9	40P-2202	WIRE TOP SIDE BALL SWG 3/32	2	-
10	40P-2203	WIRE TOP SIDE BALL SWG 1/8	-	2
11	40P-2301	WIRE TOP FRONT BALL SWG 3/32	1	1
12	40P-2401	WIRE TOP REAR BALL SWG 3/32	1	1
13	40P-4101	WIRE BRIDLE PIGTAIL	1	1
14	45G-3056	SOCK ELASTIC KP BASE WHITE	1	1

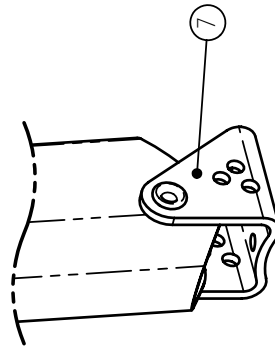
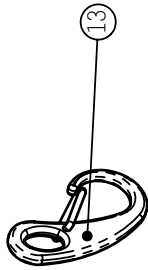
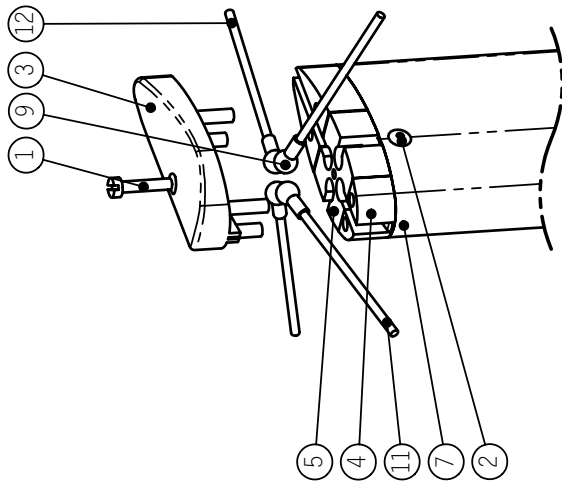

WALLS WANG
 500 BLUERIDGE AVE • ORANGE, CA 92865 • PH/FAX (714) 998-6359 / 998-0647

TITLE: **Falcon 2 Kingpost Assembly**

SLDNO: **Falcon 2 Kingpost Assy**

DOCUMENT ID:

DRAWN: **4/18/2005**

REVISED:

STATUS: **PEARSON**

REVISION: **B**

Item	Qty	Part No	Rev	Part Name
1	1	20G-3301	A	Falcon Tandem Tailboom Keel Bracket
2	1	40B-1221	A	Keel 7075 - Falcon Tandem Tailwheel
3	2	20G-3302	A	Falcon Tandem Tailwheel Plate
4	4	15F-1404		STAND-OFF 1/4
5	2	10A-2271		AN4-27A
6	2	10U-1140		WASHER STEEL AN960-416 1/4 THICK
7	5	10N-1740		CLINCH NUT 1/4 MS21042-4
8	2	10A-2171		AN4-17A
9	1	20G-3303		Falcon Tandem Tailwheel Axle
11	2	15B-1115		ENDCAP 1 1/8 .058
12	2	40P-4461		WIRE - FALCON TANDEM TAILBOOM TO CB
13	1	10A-2231		AN4-23A
14	1	70M-1025	-	WHEEL FINSTER W/ BUSH 1.125 ID
16	2	10G-1370		MS20392-2C-37
17	2	10P-1100		SAFETY RING AN 9491 SMALL
18	1	40P-4461		Wire - Falcon Tandem Tail Boom to Keel wire

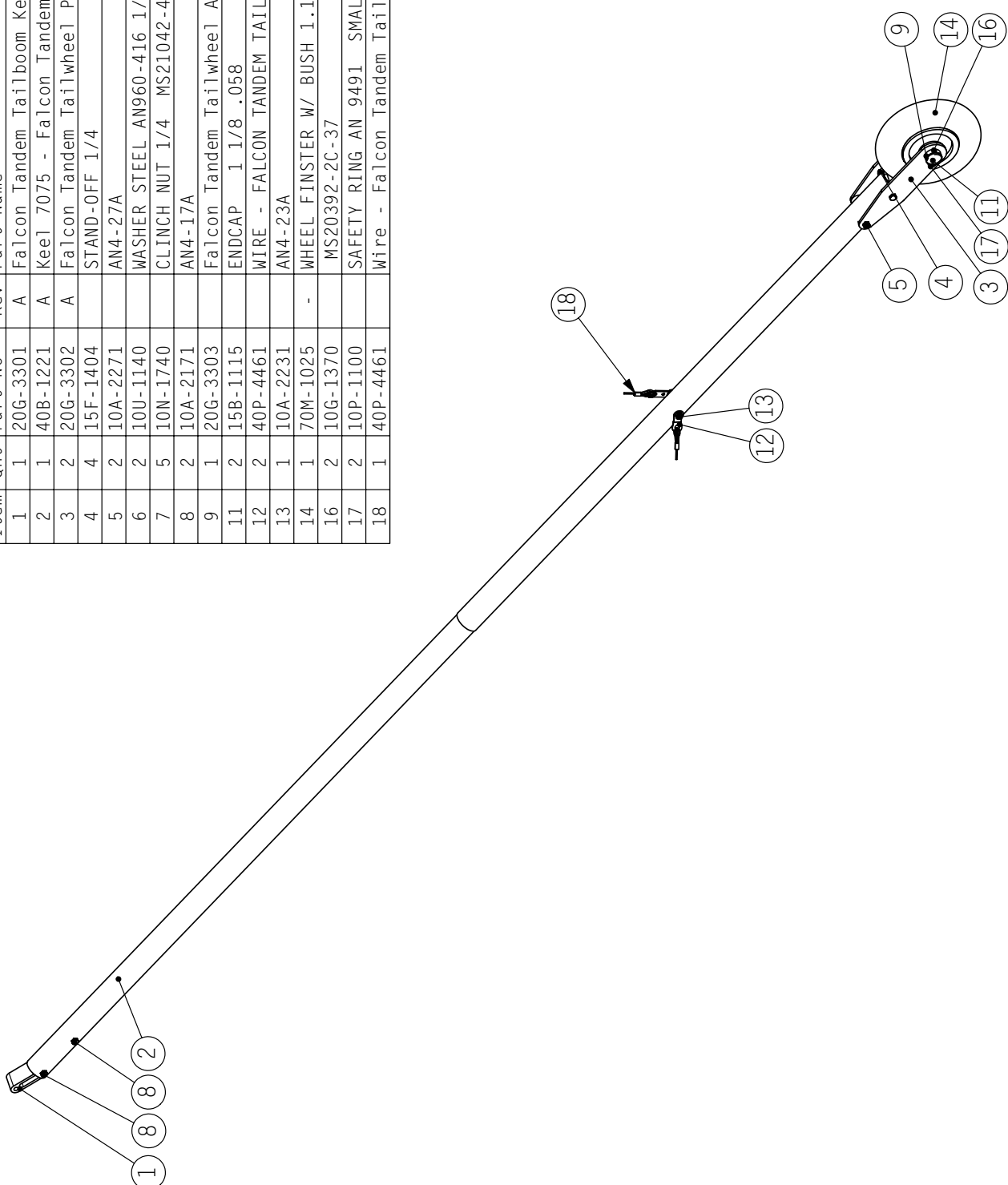

WALLS WINGS
 500 BLUERIDGE AVE • ORANGE, CA 92865 • PH/FAX (714) 998-6359 / 998-0647

TITLE: **Falcon Tandem Tailboom Assy**
 SLDWDF ID: Falcon Tandem Wheel Boom

MATERIAL:
 DRAWN: 4/17/2003
 REVISED: 4/17/2005
 STATUS:
 BY: PEARSON

PART NO: **20G-3304**
 REVISION: **B**
 T.U.S. .X ± .05
 .XX ± .015
 .XXX ± .003
 .XXXX ± .0005
 ANGLES ± 1/2°

MODEL	ID	DESCRIPTION	OAL	MATERIAL SPEC	INNERSLEEVE SPEC
ROUND BASETUBE 0.065 WALL					
F140, F2 140	40F-1310	BASETUBE AT 60 STRAIGHT	49.50	SD 6061-T6 1.1250D*.065t	NA
F170, F2 170	40F-1320	BASETUBE AT 62 STRAIGHT	51.00		
F195, F2 195, F2 225	40F-1330	BASETUBE AT 65 STRAIGHT	53.50		
F225	40F-1350	BASETUBE AT 68+4 STRAIGHT	60.00		
ROUND BASETUBE 0.095 WALL					
F140, F2 140	40F-1316	BASETUBE AT 60 STRAIGHT .095	49.50	SD 6061-T6 1.1250D*.095t	NA
F170, F2 170	40F-1326	BASETUBE AT 62 STRAIGHT .095	51.00		
F195, F2 195, F2 225	40F-1336	BASETUBE AT 65 STRAIGHT .095	53.50		
F225	40F-1356	BASETUBE AT 68+4 STRAIGHT.095	60.00		
Falcon Tandem	40F-1360	BASETUBE 1.25 X .095 X 64	64.00	SD 6061-T6 1.250D*.095t	
SPEEDBAR					
F140, F2 140	40F-1311	BASETUBE AT 60 SPEEDBAR	49.50	SD 6061-T6 1.1250D*.065t	NA
F170, F2 170	40F-1321	BASETUBE AT 62 SPEEDBAR	51.00		
F195, F2 195, F2 225	40F-1331	BASETUBE AT 65 SPEEDBAR	53.50		
F225	40F-1351	BASETUBE AT 68+4 SPEEDBAR	60.00		
FOLDING SPEEDBAR					
F140, F2 140	40F-1315	BASE CPLT ASSY AT60 FOLD NO BR	49.50	SD 6061-T6 1.1250D*.065t	NA
F170, F2 170	40F-1325	BASE CPLT ASSY AT62 FOLD NO BR	51.00		
F195, F2 195, F2 225	40F-1335	BASE CPLT ASSY AT65 FOLD NO BR	53.50		
F225	40F-1355	BASE CPL ASSY AT68+4 FLD NO BR	60.00		
ROUND LEG					
F140, F2 140	40G-1210	LEG AT 60 .065 ROUND	60.00	SD 6061-T6 1.1250D*.065t	NA
F170, F2 170	40G-1220	LEG AT 62 .065 ROUND	62.00	SD 6061-T6 1.1250D*.065t	NA
F2 195	40G-1230	LEG AT 65 .065 ROUND	65.00	SD 6061-T6 1.1250D*.065t	NA
F195, F2 225	40G-1231	LEG AT 65 .065 ROUND w/ SLEEVE	65.00	SD 6061-T6 1.1250D*.065t	SD 6061-T6 0.9930D*.025t
F225	40G-1240	LEG AT 68 .065 ROUND w/ SLEEVE	68.00	SD 6061-T6 1.1250D*.065t	SD 6061-T6 0.9930D*.025t
Falcon Tandem	40G-1250	LEG 68 ROUND 1.25 X .095	68.00	SD 6061-T6 1.250D*.095t	NA
STREAMLINE LEG					
F140, F2 140	40G-1310	LEG AT 60 STREAMLINE	60.00	EP 6063-T6 WW 1.0*2.0*.035t	NA
F170, F2 170	40G-1320	LEG AT 62 STREAMLINE	62.00	EP 6063-T6 WW 1.0*2.0*.035t	NA
F195, F2 195, F2 225	40G-1335	LEG AT 65 STREAMLINE	65.00	EP 6063-T6 WW 1.0*2.0*.035t	NA
F225	40G-1345	LEG AT 68 STREAMLINE	68.00	EP 6063-T6 WW 1.0*2.0*.035t	NA
(SD)Seamless Drawn (EP)Extruded Profile (OD)Outside Diameter (mm)Millimeter (t)hick (NA)not applicable (OAL)over all length					

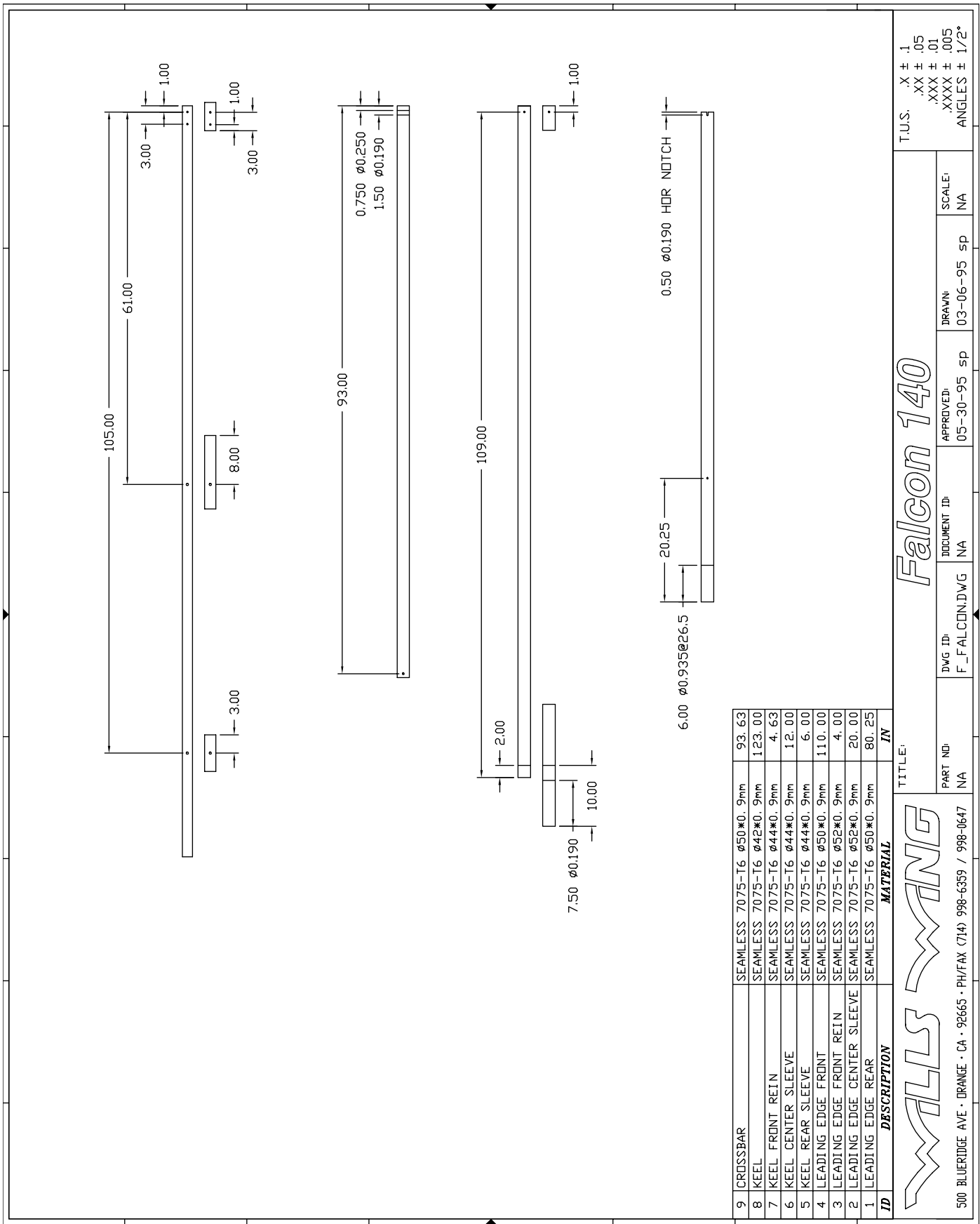

T.U.S. .X ± .1
 .XX ± .05
 .XXX ± .01
 .XXXX ± .005
 ANGLES ± 1/2°

SCALE: NA

DRAWN: 03-06-95 sp

APPROVED: 05-30-95 sp

DOCUMENT ID: NA

DWG ID: F_FALCON.DWG

PART NO: NA

TITLE: Falcon 140

500 BLUERIDGE AVE. • DRANGE • CA • 92665 • PH/FAX (714) 998-6359 / 998-0647

WALLS WANG

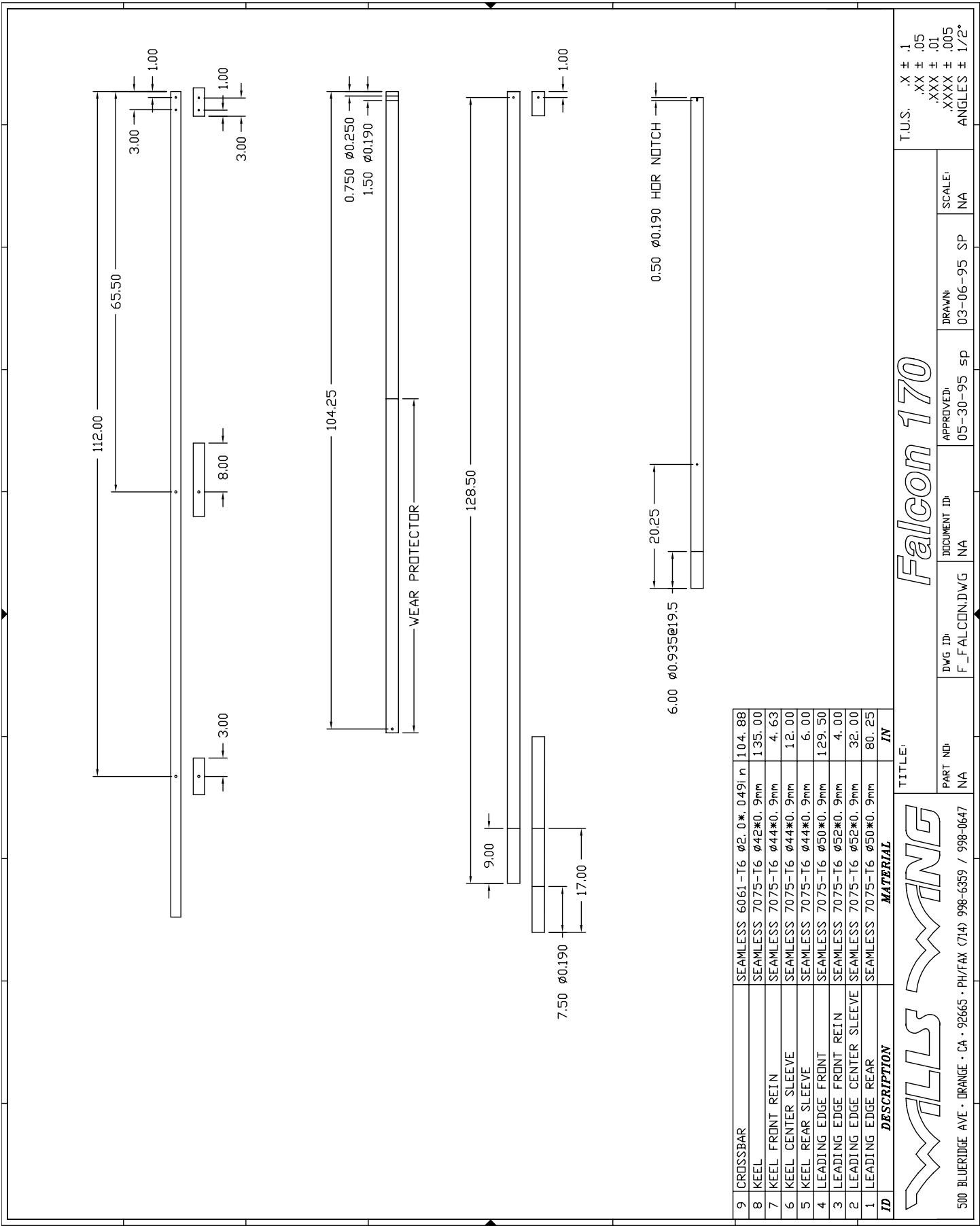

ID	DESCRIPTION	MATERIAL	IN
9	CROSSBAR	SEAMLESS 6061-T6 $\phi 2.0 \times 0.491$ in	104.88
8	KEEL	SEAMLESS 7075-T6 $\phi 42 \times 0.9$ mm	135.00
7	KEEL FRONT REIN	SEAMLESS 7075-T6 $\phi 44 \times 0.9$ mm	4.63
6	KEEL CENTER SLEEVE	SEAMLESS 7075-T6 $\phi 44 \times 0.9$ mm	12.00
5	KEEL REAR SLEEVE	SEAMLESS 7075-T6 $\phi 44 \times 0.9$ mm	6.00
4	LEADING EDGE FRONT	SEAMLESS 7075-T6 $\phi 50 \times 0.9$ mm	129.50
3	LEADING EDGE FRONT REIN	SEAMLESS 7075-T6 $\phi 52 \times 0.9$ mm	4.00
2	LEADING EDGE CENTER SLEEVE	SEAMLESS 7075-T6 $\phi 52 \times 0.9$ mm	32.00
1	LEADING EDGE REAR	SEAMLESS 7075-T6 $\phi 50 \times 0.9$ mm	80.25

FALCON 170

TITLE: **Falcon 170**

DWG ID: F_FALCON.DWG	DOCUMENT ID: NA	APPROVED: 05-30-95 sp	DRAWN: 03-06-95 SP	SCALE: NA
PART NO: NA	T.U.S. X \pm .1 .XX \pm .05 .XXX \pm .01 .XXXX \pm .005 ANGLES \pm 1/2"			

500 BLUERIDGE AVE • DRANGE • CA • 92665 • PH/FAX (714) 998-6359 / 998-0647

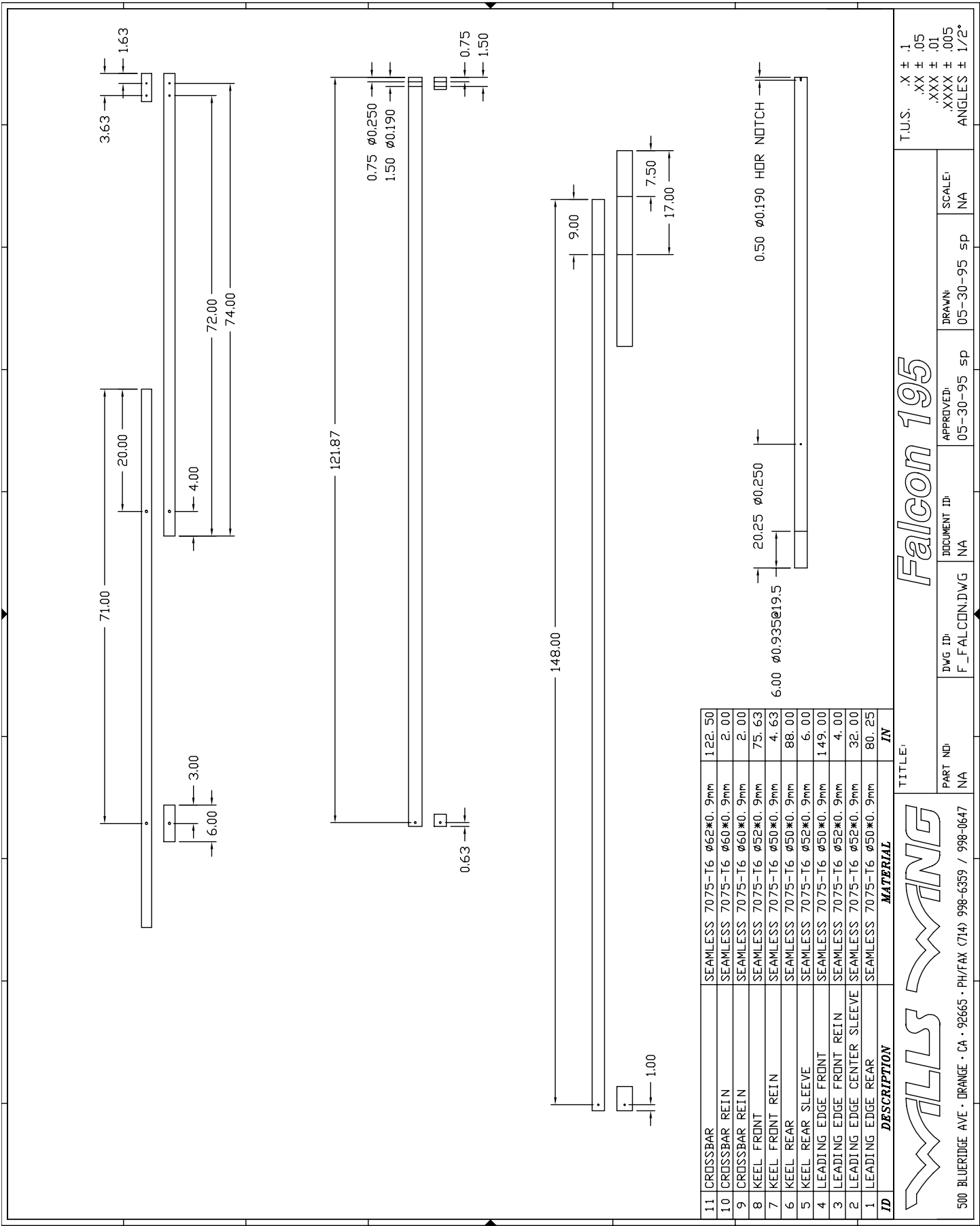

T.U.S. .X \pm .1
 .XX \pm .05
 .XXX \pm .01
 .XXXX \pm .005
 ANGLES \pm 1/2°

SCALE: NA

DRAWN: 05-30-95 sp

APPROVED: 05-30-95 sp

DOCUMENT ID: NA

DWG ID: F_FALCON.DWG

PART NO: NA

TITLE: Falcon 195

500 BLUERIDGE AVE • DRANGE • CA • 92665 • PH/FAX (714) 998-6359 / 998-0647

WALLS WING

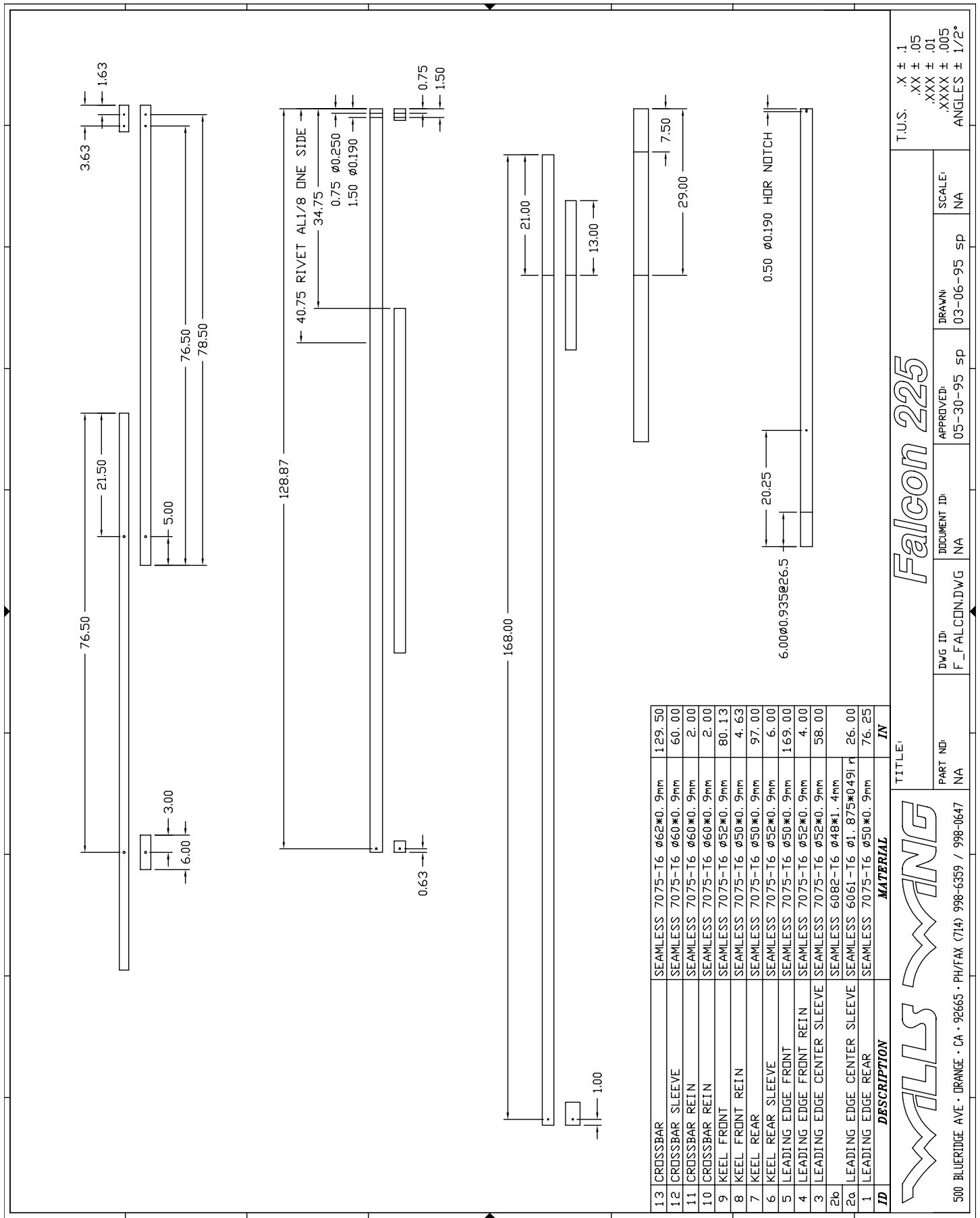

ID	DESCRIPTION	MATERIAL	IN
13	CROSSBAR	SEAMLESS 7075-T6 Ø62*0.9mm	129.50
12	CROSSBAR SLEEVE	SEAMLESS 7075-T6 Ø60*0.9mm	60.00
11	CROSSBAR REIN	SEAMLESS 7075-T6 Ø60*0.9mm	2.00
10	CROSSBAR REIN	SEAMLESS 7075-T6 Ø60*0.9mm	2.00
9	KEEL FRONT	SEAMLESS 7075-T6 Ø52*0.9mm	80.13
8	KEEL FRONT REIN	SEAMLESS 7075-T6 Ø50*0.9mm	4.63
7	KEEL REAR	SEAMLESS 7075-T6 Ø50*0.9mm	97.00
6	KEEL REAR SLEEVE	SEAMLESS 7075-T6 Ø52*0.9mm	6.00
5	LEADING EDGE FRONT	SEAMLESS 7075-T6 Ø50*0.9mm	169.00
4	LEADING EDGE FRONT REIN	SEAMLESS 7075-T6 Ø52*0.9mm	4.00
3	LEADING EDGE CENTER SLEEVE	SEAMLESS 7075-T6 Ø52*0.9mm	58.00
2b	LEADING EDGE CENTER SLEEVE	SEAMLESS 6082-T6 Ø48*1.4mm	
2a	LEADING EDGE CENTER SLEEVE	SEAMLESS 6061-T6 Ø1.875*0.491	26.00
1	LEADING EDGE REAR	SEAMLESS 7075-T6 Ø50*0.9mm	76.25

WALLS WINGS

Falcon 225

T.U.S. .X ± .1
.XX ± .05
.XXX ± .01
.XXXX ± .005
ANGLES ± 1/2°

DWG ID:	DOCUMENT ID:	APPROVED:	DRAWN:	SCALE:
F_FALCON.DWG	NA	05-30-95 sp	03-06-95 sp	NA
PART NO:	NA			

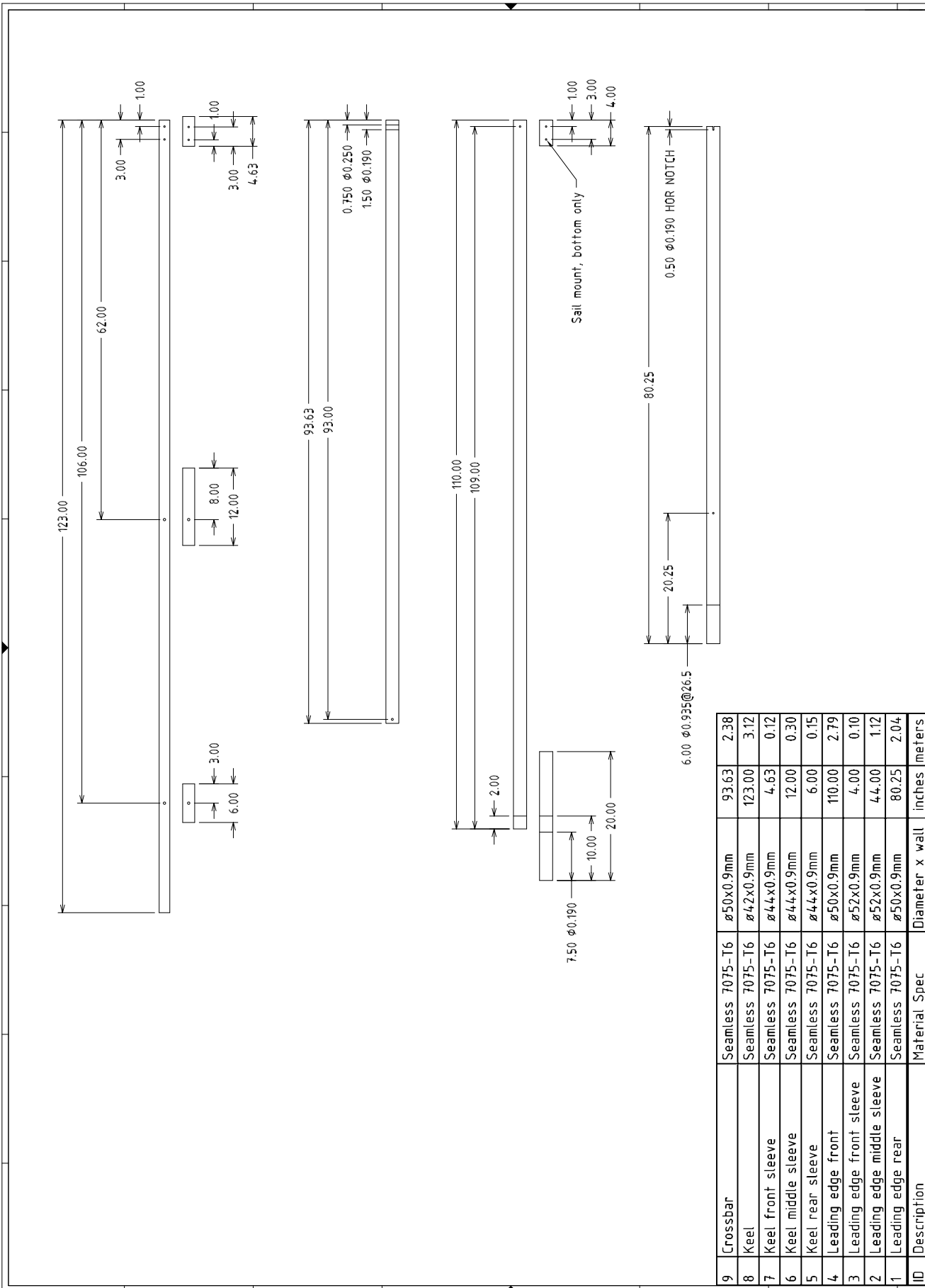

9	Crossbar	Seamless 7075-T6	Ø50x0.9mm	93.63	2.38
8	Keel	Seamless 7075-T6	Ø42x0.9mm	123.00	3.12
7	Keel front sleeve	Seamless 7075-T6	Ø44x0.9mm	4.63	0.12
6	Keel middle sleeve	Seamless 7075-T6	Ø44x0.9mm	12.00	0.30
5	Keel rear sleeve	Seamless 7075-T6	Ø44x0.9mm	6.00	0.15
4	Leading edge front	Seamless 7075-T6	Ø50x0.9mm	110.00	2.79
3	Leading edge front sleeve	Seamless 7075-T6	Ø52x0.9mm	4.00	0.10
2	Leading edge middle sleeve	Seamless 7075-T6	Ø52x0.9mm	44.00	1.12
1	Leading edge rear	Seamless 7075-T6	Ø50x0.9mm	80.25	2.04
ID	Description	Material Spec	Diameter x wall	inches	meters

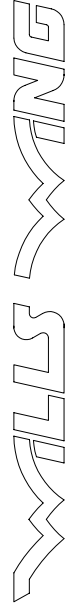

500 BLUERIDGE AVE · ORANGE · CA · 92665 · PH/FAX (714) 998-6359 / 998-0647

Falcon 2 140

TITLE: **Falcon 2 140**
 DOCUMENT ID: NA
 APPROVED: 09-12-2002 sp
 DRAWN: 02-27-2002 sp
 SCALE: NA

T.U.S. X ± 1
 .XX ± .05
 .XXX ± .01
 .XXXX ± .005
 ANGLES ± 1/2°

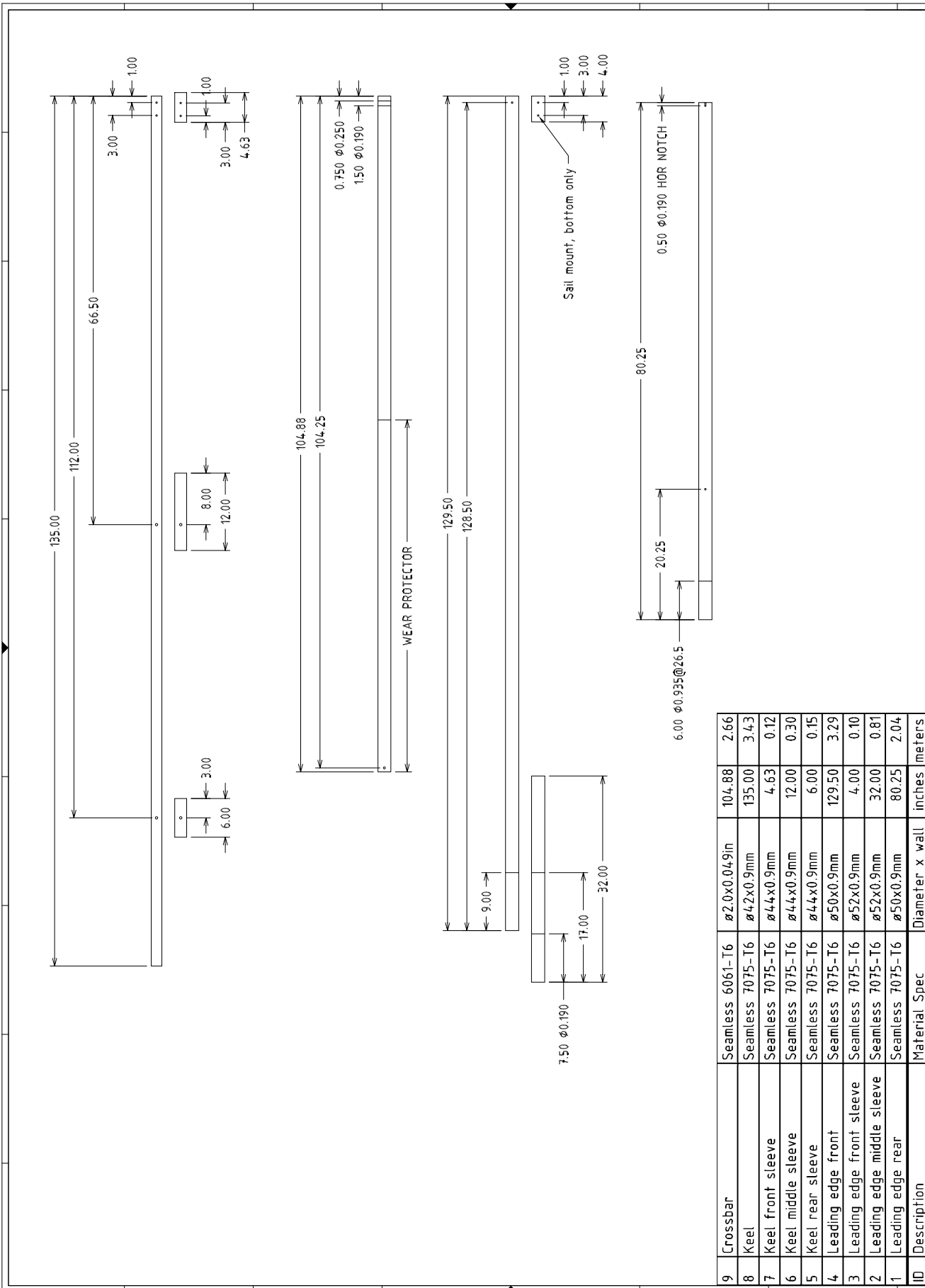

9	Crossbar	Seamless 6061-T6	ϕ 2.0x0.049in	104.88	2.66
8	Keel	Seamless 7075-T6	ϕ 4.2x0.9mm	135.00	3.43
7	Keel front sleeve	Seamless 7075-T6	ϕ 4.4x0.9mm	4.63	0.12
6	Keel middle sleeve	Seamless 7075-T6	ϕ 4.4x0.9mm	12.00	0.30
5	Keel rear sleeve	Seamless 7075-T6	ϕ 4.4x0.9mm	6.00	0.15
4	Leading edge front	Seamless 7075-T6	ϕ 50x0.9mm	129.50	3.29
3	Leading edge front sleeve	Seamless 7075-T6	ϕ 52x0.9mm	4.00	0.10
2	Leading edge middle sleeve	Seamless 7075-T6	ϕ 52x0.9mm	32.00	0.81
1	Leading edge rear	Seamless 7075-T6	ϕ 50x0.9mm	80.25	2.04
ID	Description	Material Spec	Diameter x wall	inches	meters

WALLS WINDING

500 BLUERIDGE AVE · ORANGE · CA · 92665 · PH/FAX (714) 998-6359 / 998-0647

Falcon 2 170

TITLE

PART NO: NA

DWG ID: F_FALCONDWG

DOCUMENT ID: NA

APPROVED: 09-12-2002 sp

DRAWN: 02-27-2002 sp

SCALE: NA

T.U.S. X ± 1
 .XX ± .05
 .XXX ± .01
 .XXXX ± .005
 ANGLES ± 1/2°

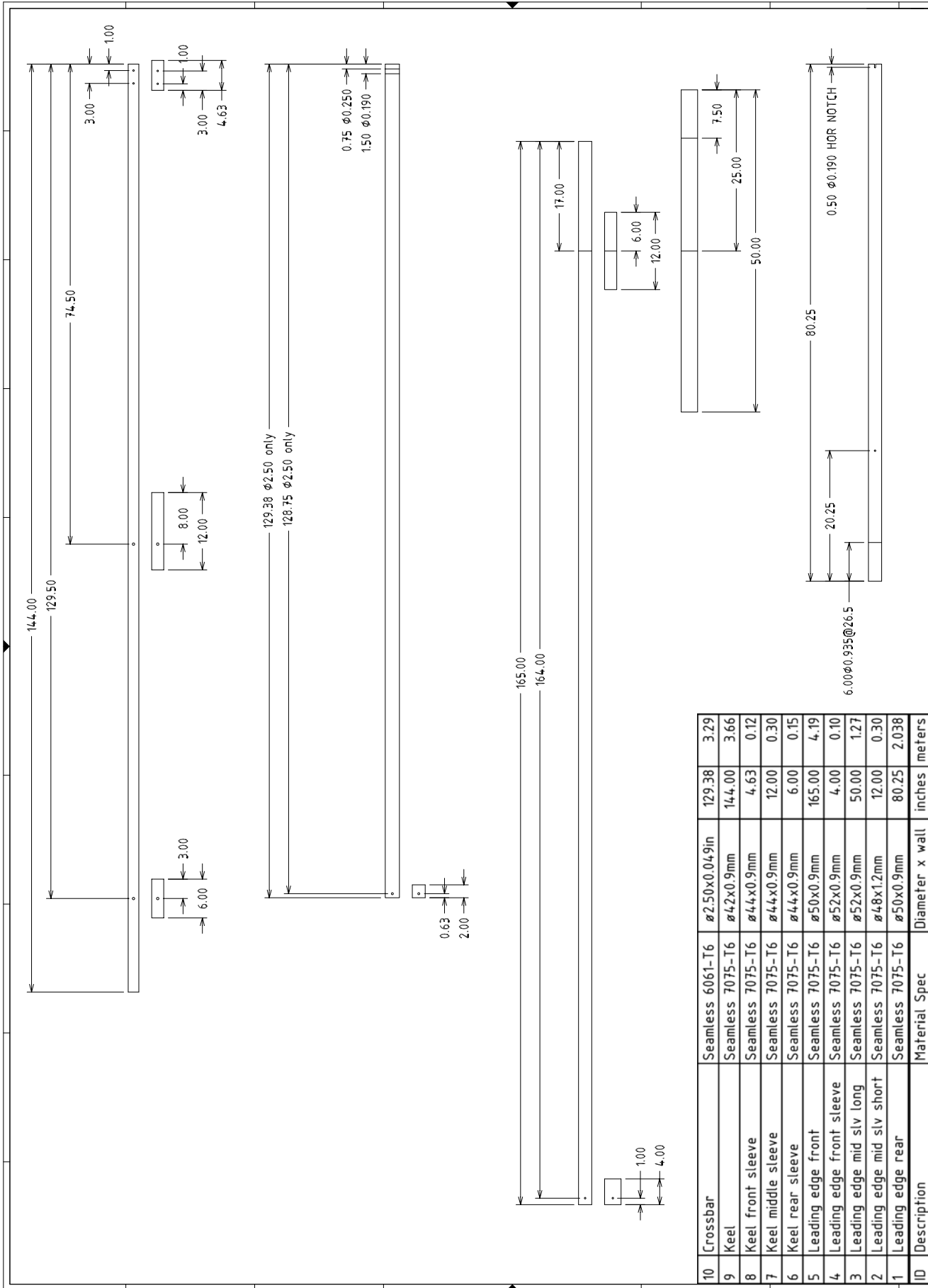

10	Crossbar	Seamless 6061-T6	Ø2.50x0.04.9in	129.38	3.29
9	Keel	Seamless 7075-T6	Ø4.2x0.9mm	144.00	3.66
8	Keel front sleeve	Seamless 7075-T6	Ø4.4x0.9mm	4.63	0.12
7	Keel middle sleeve	Seamless 7075-T6	Ø4.4x0.9mm	12.00	0.30
6	Keel rear sleeve	Seamless 7075-T6	Ø4.4x0.9mm	6.00	0.15
5	Leading edge front	Seamless 7075-T6	Ø50x0.9mm	165.00	4.19
4	Leading edge front sleeve	Seamless 7075-T6	Ø52x0.9mm	4.00	0.10
3	Leading edge mid slv long	Seamless 7075-T6	Ø52x0.9mm	50.00	1.27
2	Leading edge mid slv short	Seamless 7075-T6	Ø48x1.2mm	12.00	0.30
1	Leading edge rear	Seamless 7075-T6	Ø50x0.9mm	80.25	2.038
ID	Description	Material Spec	Diameter x wall	inches	meters



500 BLUERIDGE AVE · ORANGE · CA · 92665 · PH/FAX (714) 998-6359 / 998-0647

Falcon 2 225

T.U.S. X ± .1
.XX ± .05
.XXX ± .01
.XXXX ± .005
ANGLES ± 1/2°

DRAWN: 03-25-2002 sp
SCALE: NA

APPROVED: 09-12-2002 sp

DOCUMENT ID: NA

DWG ID: F_FALCONDWG

PART NO: NA

TITLE

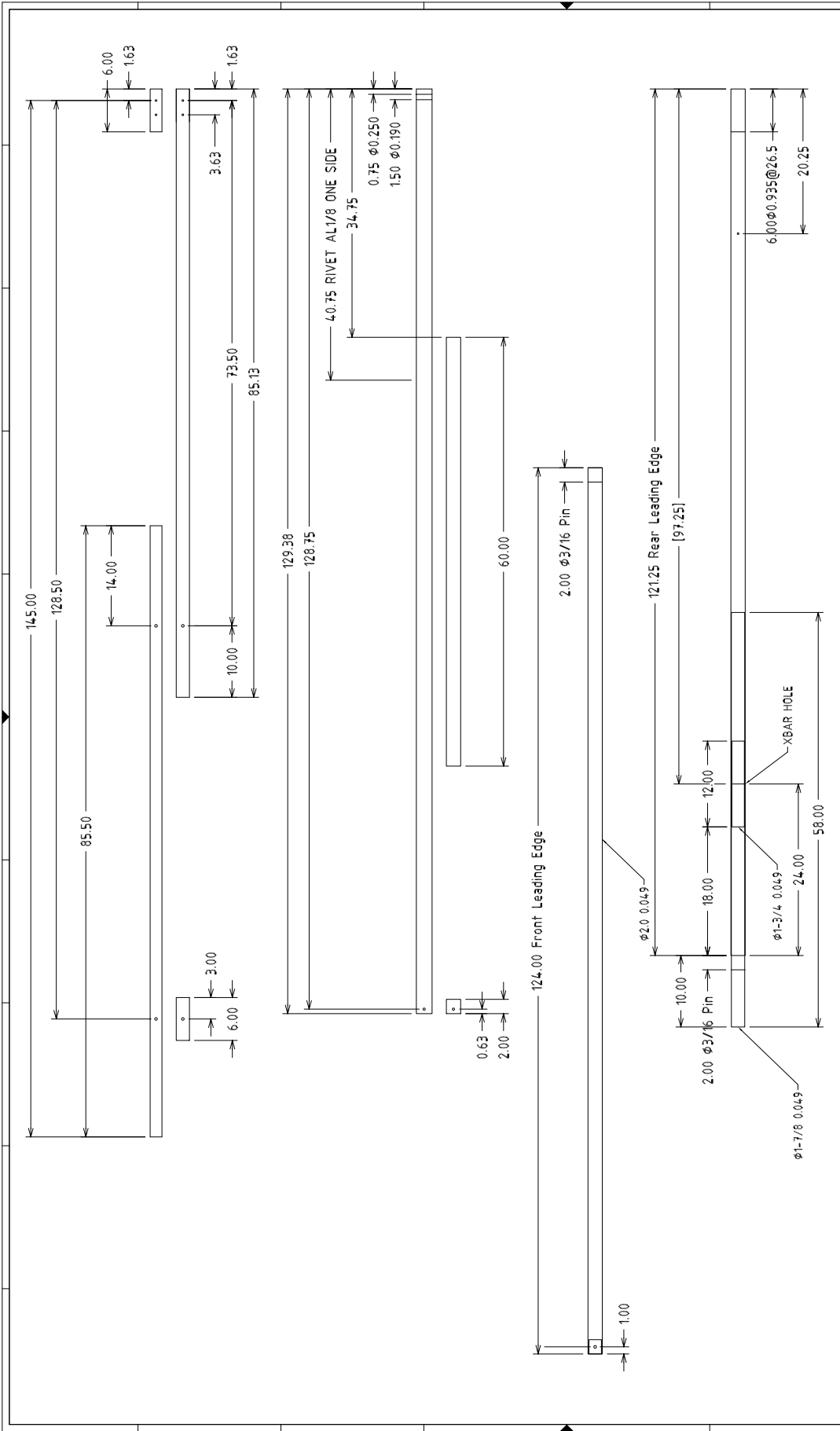

11	Crossbar (standard)	Seamless 7075-T6	$\phi 62 \times 0.9 \text{mm}$	129.38	3.29
10b	Crossbar (alternate)	Seamless 7075-T6	$\phi 62 \times 0.9 \text{mm}$	129.38	3.29
10a	Crossbar Sleeve	Seamless 7075-T6	$\phi 60 \times 0.9 \text{mm}$	60.00	1.52
9	Keel front	Seamless 7075-T6	$\phi 52 \times 0.9 \text{mm}$	85.13	2.16
8	Keel rear	Seamless 7075-T6	$\phi 50 \times 0.9 \text{mm}$	85.50	2.17
7	Keel front sleeve	Seamless 7075-T6	$\phi 50 \times 0.9 \text{mm}$	6.00	0.15
6	Keel rear sleeve	Seamless 7075-T6	$\phi 52 \times 0.9 \text{mm}$	6.00	0.152

5	Leading edge front	Seamless 6061-T6	$\phi 2.00 \times 0.049 \text{in}$	124.00	3.15
4	Leading edge front sleeve	Seamless 6061-T6	$\phi 1.88 \times 0.049 \text{in}$	4.00	0.10
3	Leading edge short mid slv	Seamless 6061-T6	$\phi 1.75 \times 0.058 \text{in}$	12.00	0.30
2	Leading edge long mid slv	Seamless 6061-T6	$\phi 1.88 \times 0.049 \text{in}$	58.00	1.47
1	Leading edge rear	Seamless 6061-T6	$\phi 2.00 \times 0.049 \text{in}$	121.5	3.086
ID	Description	Material Spec	Diameter x wall	inches	meters

T.U.S.

.X ± 1
 .XX $\pm .05$
 .XXX $\pm .01$
 .XXXX $\pm .005$
 ANGLES $\pm 1/2^\circ$

Falcon Tandem

TITLE



PART NO: NA
 DWG ID: F_FALCON.DWG
 APPROVED: 09-12-2002 sp
 DRAWN: rev 05-13-2002 sp
 SCALE: NA
 DOCUMENT ID: NA